

Enerwa Plus 2500 H

Enerwa Plus 3000 H

Enerwa Plus 3500 H

**WALL MOUNTED CONDENSING SYSTEM BOILERS
INSTALLATION & USER MANUAL**



Enerwa*Plus* 2500 H
Enerwa*Plus* 3000 H
Enerwa*Plus* 3500 H





INDEX

1.	DEAR WARMHAUS CUSTOMER	4
1.1.	GENERAL WARNINGS	4
1.2.	TERMS AND CONDITIONS OF WARRANTY	4
1.3.	GAS LEAKS	5
1.4.	CONTENTS OF THE PACKING BOX	5
1.5.	BOILER GAS CATEGORIES & DESTINATIONS	6
2.	INSTALLATION PERSONNEL SECTION	7
2.1.	BOILER INSTALLATION RULES	7
2.1.1.	General Rules for Installation Place of the Boiler	7
2.1.2.	Places where hermetic boilers cannot be installed	7
2.1.3.	Dimensions and Connections	7
2.1.4.	Mounting of the Boiler to Wall and Selection of Installation Place	8
2.1.5.	Natural Gas Connection (Appliance Category I _{2H})	8
2.1.6.	Flammable Gas Quality	8
2.1.7.	Heating and Domestic Hot Water Installations	8
2.1.8.	Filling the flusher for Condensation Line	10
2.1.9.	Exhaust Gas Flue Pipe Set and Accessories Connection	10
2.1.10.	Peripheral Distances of the Flue Outlet Connections	10
2.1.11.	Installation with (Ø80/125 mm) horizontal homocentric flue sets Connection of (Ø80/125 mm) horizontal homocentric flue set to the boiler	10
2.1.12.	Installation with Vertical Concentric Flue Sets	15
2.1.13.	Use of Split Flue Type (Hermetic)	15
2.1.14.	Installation at Partially Protected Outsides	18
2.1.15.	Electrical Connections	19
2.1.16.	Optional Controls: Room Thermostat, Outside Temperature Sensor, Connections and Installation	19
2.2.	HYDRAULIC INSTALLATION RULES	20
2.2.1.	Heating System Water	20
2.2.2.	Filling/Draining the Heating System	20
2.2.3.	Drainage of the Condensate Water	20
2.2.4.	Circulation Pump (Optional)	20
2.2.5.	Checks for Start-up of the Boiler	22
2.3.	FITTINGS REQUIRED FOR OPERATION OF THE BOILER AND HEATING SYSTEM	22
2.3.1.	The Boiler Pumps	22
2.4.	SAMPLE INSTALLATION SCHEME	23
2.4.1.	Components of the Boiler	26
3.	FOR USERS	26
3.1.	GENERAL WARNINGS FOR USERS	26
3.1.1.	Use of the Boiler	26
3.2.	SELECTION OF ON / OFF / STAND-BY AND SUMMER / WINTER MODES	26
3.2.1.	On/Off/Stand-by Positions	26
3.2.2.	Operation in Winter Mode	27
3.2.3.	Operation in Summer Mode	27
3.2.4.	Resetting the Boiler (Restart)	27
3.2.5.	Turning off the Boiler	27
3.2.6.	Selection of On/Off/Stand-by and Summer/Winter Modes	27
3.2.7.	On/Off/Stand-by Positions	28
3.2.8.	Operation in Winter Mode	28
3.2.9.	Operation in Summer Mode (if a boiler is fitted);	29
3.2.10.	Use with Room Thermostat (Optional)	29
3.2.11.	Use of Outside Temperature Sensor (Optional)	29
3.2.12.	Customization of Boiler Functions	29
3.3.	TROUBLE SHOOTING	30
3.3.1.	Error Code Table	30
3.4.	RECOMMENDATIONS FOR ECONOMICAL USE OF THE BOILER	34
3.5.	MATTERS TO PAY ATTENTION FOR GUARANTEE CONDITIONS	34



1. DEAR WARMHAUS CUSTOMER

We congratulate and thank you for choosing Warmhaus wall mounter boiler which shall provide you heating and domestic hot water comfort for years. State-of-art Warmhaus boilers, being manufactured in compliance with standards of the European Union are also exported to many countries. You can utilize our Authorized Technical Service network with professional competence certification for any ordinary maintenance needs of this product produced meticulously with hard work. Our authorized services assure sustaining performance of the device as they shall always provide original spare part services. Please read this manual thoroughly to use your boiler economically, comfortably and efficiently, and store to refer when needed.

It is recommended for efficient use to have assembly done by an authorized dealer approved by the local gas authority and which has the competence and experience for assembly.

1.1. GENERAL WARNINGS

This manual is an integral part of the product, and must be delivered to the new user in case of handover of the appliance. The manual shall be preserved properly and kept in the way to be referred as it contains significant information about use as well as installation of the appliance.



Heating and Domestic Hot Water installations shall be projected and implemented a competent and approved engineering company meeting the criteria prescribed by laws, by observing the current legislation in force.



Installation and maintenance shall be carried out by the competent personnel having sufficient knowledge in the installation industry and professional competence certification in accordance with the legislation in force and in line with the directions of the manufacturer. Hazards which may cause injury of persons, other living beings (animals, plants) and damage to goods may be caused by wrong installation, for which the manufacturer cannot be held responsible.



Natural gas installation project; shall be carried out by one of the dealers authorized by your local gas authority.



Attention! Please note & read the warning and information's on the boiler. Incorrect operation of the boiler can cause significant damage.

For Warmhaus wall-mounted boilers; commissioning, adjustment, maintenance and cleaning must only be carried out by a specialist OR approved service by Warmhaus!

When faults occur in the heating system, the plant must be stopped and damaged parts should only be replaced by an authorized workshop.

The accessories used must correspond to the technical rules and the relevant parts must be approved by the manufacturer in connection with the Warmhaus wall-mounted boiler.

Only APPROVED & ORIGINAL spare parts should be used.

Bolts sealed with paint strictly forbidden to open !



The boiler must not be used by children younger 8 years or invalid persons without supervision.

These seals provide evidence that the replacement of bolts required for safe operation. If the seals are damaged, the guarantee of the device will come to an end!

1.2. TERMS AND CONDITIONS OF WARRANTY



The manufacturer may not be held responsible for any faults caused by noncompliance to the legislation and standards in force and information provided in this manual (and information and instructions provided by the manufacturer in any case), within or out of the scope of the contract, and this also constitute reason for termination of warranty of the appliance.



Only Warmhaus Authorized Service is authorized to carry out electrical connection of the boiler and to energize the boiler.

In case of any material, design or installation faults occurred within the warranty period, maintenance and operation shall be carried out without any charge of labor or spare parts.

(Also see: 3.5 MATTERS TO PAY ATTENTION FOR GUARANTEE CONDITIONS)



This appliance should only be used for its designed intended purposes (to be used in closed-circuit heater installation and production of open circuit domestic hot water production). All kinds of other uses are not suitable as well as may create a potential danger.



Manufacturer shall not be responsible for damages occurring due to interventions, false installation and initial starting performed by unauthorized persons and warranty scope shall be void. As the Combi is an appliance having heating system, domestic hot water, natural gas/LPG and electrical connections, do not make and have any interventions made without the authorized service



This appliance maintenance operations should be performed by the authorized and competent technical personnel, and Warmhaus Authorized Technical Service Center's constitute assurance for quality. WARMHAUS is not responsible for damages arising from repairs, part replacements and maintenance performed by third persons and companies and combi remains out of the warranty scope under such conditions.



This appliance has been manufactured to be installed in the country specified on its technical registration label. Installing the appliance in any other country than those specified on the plate may cause damage or injury to persons, animals and goods.

WARMHAUS declares that Enerwa Plus 1800 H - 2500 H - 3000 H - 3500 H boilers comply with the essential requirements of the following directives:

- Gas Appliances Regulation (EU) 2016/426
- Boiler Efficiency Directive 92/42/EEC
- Electromagnetic Compatibility Directive 2014/30/UE
- Low Voltage Directive 2014/35/UE
- Ecodesign Directive 2009/125/EC
- Regulation (EU) N. 813/2013 - 811/2013

Manufacturer: Warmhaus Isıtma ve Soğutma Sistemleri Tic. A.Ş. Bursa Işıktepe OSB Mah. Park Cad. No:10 16140 Nilüfer-Bursa / Turkey

WARMHAUS

24 kW, 28 kW, 33 kW



1015 18

WARMHAUS A.Ş. reserves the right to make all kinds of technical and



commercial modifications without notice, and disclaims any liabilities arising out of printing and spelling mistakes.

IMPORTANT INFORMATION

It is a statutory requirement that all gas appliances are installed by competent persons, in accordance with the gas safety (installation and use) regulations (current edition). The manufacturer's instructions must not be taken as overriding any statutory requirements, and failure to comply with these regulations may lead to prosecution. No modifications to the appliance should be made unless they are fully approved by the manufacturer. Gas leaks: do not operate any electrical switch, or use a naked flame. Turn off the gas supply and ventilate the area by opening doors and windows contact the gas emergency service

1.3. GAS LEAKS

187 NATURAL GAS EMERGENCY LINE
HOW TO ACT IN CASE OF DETECTING NATURAL GAS ODOR



Do not use lighter- matches



Do not turn on, off or unplug the lamps or other electrical appliances.



Ventilate the environment by opening doors and windows.



Close valves of appliances operating with natural gas and your gas meter



Do not use/let anyone use the doorbell.



Do not use phones in case of a natural gas leakage. It may create sparks.



Immediately evacuate the place with gas odor.



Call the Natural Gas Emergency Line from your neighbor or another suitable place.



Do not intervene the installation Wait for Gas Authorities Team to arrive.



Never close culverts ensuring discharge of the gas from the environment in case of a natural gas leakage.

IN EMERGENCY CASES



NATURAL GAS EMERGENCY



FIRE DEPARTMENT



AMBULANCE



POLICE

INFORMATION: You can visit web sites of local gas authorities and **NATURAL GAS EMERGENCY** sections.

Advice: Please take note local emergency phone numbers.

1.4. CONTENTS OF THE PACKING BOX

Warmhaus is delivered in two boxes as Boiler and Flue Set Box. The Boiler box contains the materials listed below and the small box contains

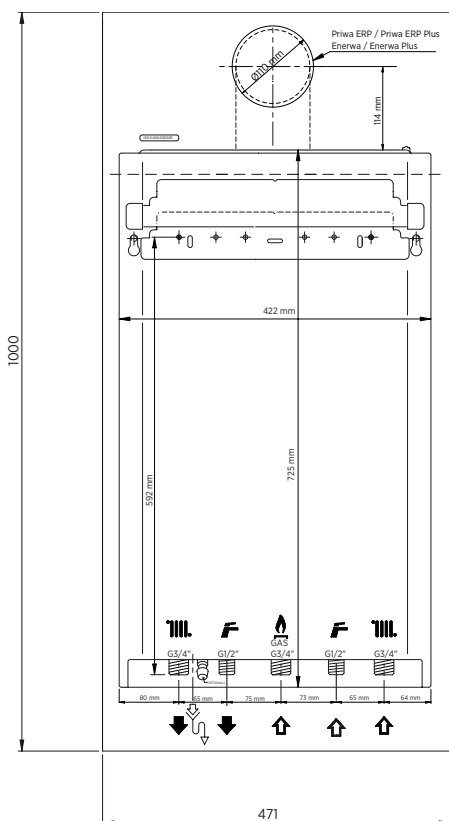

Figure 1 Installation scheme



Figure 2 Operation Manual



Figure 3 Hanger Plate and Connection Accessories



Figure 4 Exhaust gas flue set



Keep packaging materials (plastic, bag, nylon, etc.) away from children in order to avoid risks to health.



1.5. BOILER GAS CATEGORIES & DESTINATIONS

Gas categories for Warmhaus boilers has been applied on CE certification on SZU Test / BRNO given below;
 - the appliance category(ies) in relation to the direct countries of destination has been specified EN 15502-1; GAR Certificate product ID Nr. CE-1015CT0706 :18
 - EN 437+A1:2009, Codes for the representation of gases
 - the country(-ies) of destination, in accordance with EN ISO 3166-1;
 - the gas supply pressure in millibars, if several normal pressures can be used for the same gas group. They are indicated by their numerical value and the unit "mbar"

Document for conformity approved by SZU test	Appliance Categories	Gas Type	Gas Inlet Supply Pressures	Used Gas	Ewa 18/24/28/33 Priwa 24/28/33 Priwa Plus 24/28/33 Priwa ErP 18/24/28/33 Priwa Plus ErP 18/24/28/33 Priwa ErP version H and R Priwa Plus ErP version H and R	Enerwa 18/24/28/33 Enerwa 2525C/ 2530C/3035C/3540C Enerwa Plus 18/24/28/33 Enerwa Plus 2525C/ 2530C/3035C/3540C Enerwa ErP version H and R Enerwa Plus ErP version H and R	Viwa 50 Viwa 65 Viwa 90 Viwa 115 Viwa 125 Viwa 150	Countries of Destination **
YES	I _{2H}	Natural Gas	20 mbar	G20	Available	Available	Available	AT, BG, CH, CZ, DK, EE, ES, FI, GB, GR, HR, IE, IT, LT, LU, LV, NO, PT, RO, SE, SI, SK, TR
YES	I _{2H}	Natural Gas	25 mbar	G20	Available	Available	Available	HU
YES	I _{2E}	Natural Gas	20 mbar	G20	Available	Available	Available	DE, LU, PL, RO
YES	I _{2E+}	Natural Gas	20 mbar	G20	Available	Available	Not Available	BE, FR
YES	I _{2E(S)}	Natural Gas	20 mbar	G20	Available	Available	Available	BE
YES	I _{2ELL}	Natural Gas	20 mbar	G20	Available	Available	Not Available	DE
YES	II _{2H3P}	Natural Gas	20 mbar	G20	Available	Available	Not Available	CH, CZ, ES, GB, GR, HR, IE, IT, LT, PT, RO, SI, SK
YES	II _{2H3+}	Natural Gas	20 mbar	G20	Available	Available	Not Available	CH, CY, CZ, ES, GB, GR, IE, IT, LT, PT, SI, SK, TR
YES	II _{2E+3+}	Natural Gas	20 mbar	G20	Available	Available	Not Available	BE, FR
YES	II _{2E+3P}	Natural Gas	20 mbar	G20	Available	Available	Not Available	BE, FR
YES	II _{2H3B/P}	Natural Gas	20 mbar	G20	Available	Available	Not Available	AT, CH, CY, CZ, DK, EE, FI, GR, IT, LT, NO, RO, SE, SI, SK
YES	II _{2E3B/P}	Natural Gas	20 mbar	G20	Available	Available	Not Available	DE
YES	II _{2ELL3B/P}	Natural Gas	20 mbar	G20	Available	Available	Not Available	DE
YES	I _{2L}	Natural Gas	25 mbar	G20	Available	Available	Not Available	NL
YES	I _{2E+}	Natural Gas	25 mbar	G25	Available	Available	Not Available	BE, FR
YES	I _{2ELL}	Natural Gas	20 mbar	G25	Available	Available	Not Available	DE
YES	II _{2L3P}	Natural Gas	25 mbar	G25	Available	Available	Not Available	NL
YES	II _{2L3B/P}	Natural Gas	25 mbar	G25	Available	Available	Not Available	NL
YES	II _{2ELL3B/P}	Natural Gas	20 mbar	G25	Available	Available	Not Available	DE
YES	I ₃₊	Buthane Gas	28-30 mbar 37 mbar	G25	Available	Available	Not Available	BE, CH, CY, CZ, ES, FR, GB, GR, IE, IT, LT, PT, SI, SK
YES	I _{3B/P}	Buthane Gas	30 mbar	G30	Available	Available	Not Available	BE, CY, CZ, DK, EE, FI, GB, GR, HU, HR, IT, LT, NL, NO, RO, SE, SI, SK, TR
YES	I _{3B/P}	Buthane Gas	50 mbar	G30	Available	Available	Not Available	AT, CH, DE, FR, SK
YES	II _{2H3+}	Buthane Gas	28-30 mbar 37 mbar	G30	Available	Available	Not Available	CH, CY, CZ, ES, GB, GR, IE, IT, LT, PT, SI, SK, TR
YES	II _{2E+3+}	Buthane Gas	28-30 mbar 37 mbar	G30	Available	Available	Not Available	BE, FR
YES	II _{2H3B/P}	Buthane Gas	30 mbar	G30	Available	Available	Not Available	CY, CZ, DK, EE, FI, GR, IT, LT, NO, RO, SE, SI, SK
YES	II _{2H3B/P}	Buthane Gas	50 mbar	G30	Available	Available	Not Available	AT, CH, SK
YES	II _{2E3B/P}	Buthane Gas	50 mbar	G30	Available	Available	Not Available	DE
YES	II _{2L3B/P}	Buthane Gas	30 mbar	G30	Available	Available	Not Available	NL
YES	II _{2ELL3B/P}	Buthane Gas	50 mbar	G30	Available	Available	Not Available	DE
YES	I _{3P}	Propane LPG	37 mbar	G30	Available	Available	Not Available	BE, CH, CZ, ES, FR, GB, GR, HR, IE, IT, LT, NL, PL, PT, SI, SK, TR
YES	II _{2H3P}	Propane LPG	37 mbar	G31	Available	Available	Not Available	CH, CZ, ES, GB, GR, HR, IE, IT, LT, PT, RO, SI, SK
YES	II _{2L3P}	Propane LPG	37 mbar	G31	Available	Available	Not Available	NL
YES	II _{2E+3P}	Propane LPG	37 mbar	G31	Available	Available	Not Available	BE, FR

EN ISO 3166-1: 2006, Codes for the representation of names of countries and their subdivisions - Part 1: Country codes (ISO 3166-1: 2006)



Product Name (as on product data badge & installation instructions)	G.C. No Allocated by British Gas**
Enerwa 2530	47-786-01
Enerwa Plus 2530	47-786-02
Enerwa 3035	47-786-03
Enerwa Plus 3035	47-786-04
Enerwa 3540	47-786-05
Enerwa Plus 3540	47-786-06

2. INSTALLATION PERSONNEL SECTION

2.1. BOILER INSTALLATION RULES

2.1.1. General Rules for Installation Place of the Boiler

There are not any ventilation limitations for areas where hermetic (C type) boiler is to be installed (it can be installed independent of the volume and ventilation of the room). It can also be installed in protected areas like balcony and terrace provided that it is placed in a protective closure and that precautions against freezing of the system water are taken. The boiler shall be securely mounted to the building wall. A flexible joint shall be used between the boiler and gas line. Lengths of the flex ducts to be used in Type A, B and C appliances shall not exceed the values permitted by the local gas authority. Flue outlets of hermetic boilers must be connected to the areas which are directly open to outside area, and have sufficient air circulation. Conditions of exhaust gas system gas outlets of these appliances

(position of the pipe outlets in various forms, vertical, horizontal minimum distances, cross-sectional areas of ducts if used, etc.) shall be in compliance with EN 12514 standard.

2.1.2. Places where hermetic boilers cannot be installed

- Stairwells of buildings,
- common aisles, ventilation ducts, garret, attics, emergency exit doors, storage rooms and other similar common areas,
- Yards between buildings,
- Narrow gaps between eaves
- On the chimney walls,
- Closed balconies,
- Open balconies (except placed in an enclosure and permitted by the manufacturer),
- Under the extending structures hindering outlet of exhaust gas,
- Places exposed to direct wind force,
- Openings supplying fresh air to other units (C type) It is forbidden to install hermetic boilers at places specified above!

2.1.3. Dimensions and Connections

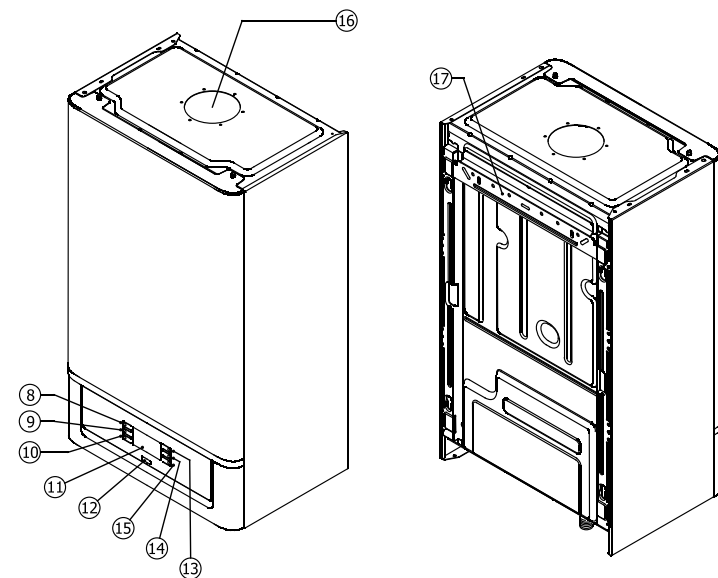

Enerwa Plus H

- 1) 230 V AC Main Power Supply
- 2) Manometer
- 3) Safety Valve Drainage Line
- 4) Gas Inlet Line
- 5) Heating Supply Line
- 6) Heating Return Line
- 7) Condensate Drainage Line
- 8) Sediment-Air Separator Discharge
- 9) Heating/Domestic Hot Water MODE Button
- 10) Heating Temperature Increasing Setting Button,

- 11) Heating Temperature Reducing Setting Button
- 12) LCD Display
- 13) Service Port
- 14) RESET Button
- 15) Domestic Hot Water Temperature Increasing Setting Button
- 16) Domestic Hot Water Temperature Reducing Setting Button
- 17) Exhaust gas/Flue outlet
- 18) Hanger plate

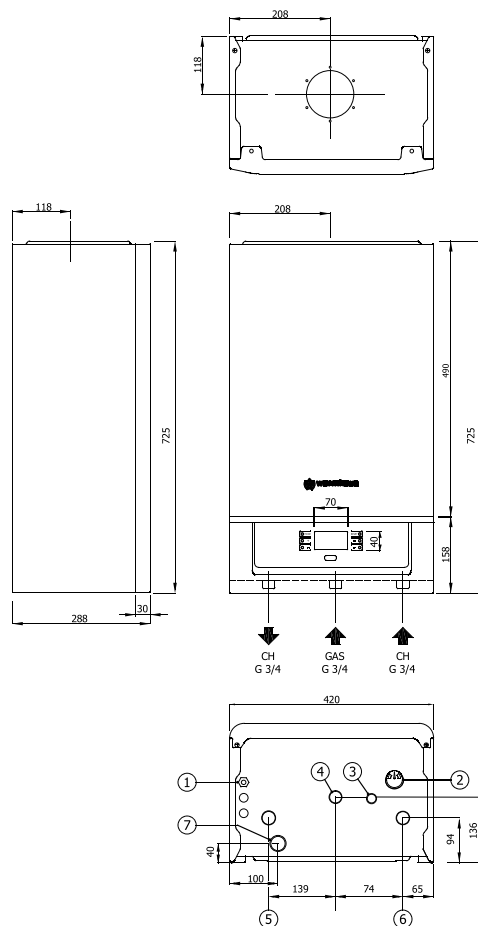

Figure 5 Enerwa Plus H boiler dimensions and connections



2.1.4. Mounting of the Boiler to Wall and Selection of Installation Place

- Mounting of the boiler to wall must be checked and ensured to be stable and safe.
- The hanger plate and connection screws supplied with the boiler shall be mounted on a filled or semi-filled brick wall in accordance with the installation scheme, and shall not be used for other purposes.
- In case any different materials are used for mounting, the warranty of the boiler shall be terminated.
- If the wall to which the boiler is to be mounted is not brick, strength of the support system shall be checked.
- The boiler shall be mounted on a fire resistant wall.
- The boiler should be mounted so as the height of the hanger plate to be between 1,8-2,2 mm from the ground.
- The boiler shall be mounted with gaps as minimum 30 cm above the ground, minimum 3 cm from both sides and minimum 90 cm from the front side where the installation area is limited, for allowing easy intervention of the service technician.
- The boiler shall not be installed in areas which contain or may contain explosives, flammables and acid vapors.
- It shall not be installed next to or above ovens, cookers, radiators or heaters.
- Hermetic boilers can also be installed in cabinets, provided that minimum 5 cm from each side is left.
- If the boiler is to be mounted over the kitchen countertop or kitchen set, there shall be a minimum 50 cm distance under the boiler.
- Due to possibility of water draining from the Safety Valve of the boiler after mounting, the outlet shall be connected to the drainage line. If this is not possible; do not place electronic appliances, and tools, parts and materials which may breakdown, be deformed or form rust.
- Any furniture should not be placed under the boiler due to the reasons specified above.
- Make sure that there are no liquids or inflammable materials in the immediate vicinity of the boiler.
- It is necessary to leave a specific distance 1.0 mt between the heating device and the building material containing combustible material even the maximum allowable temperature value of 85 °C in the rated heat capacity of the appliance is not exceeded.

2.1.5. Natural Gas Connection (Appliance Category I_{2H})

The boilers are designed to run on methane (G20) gas. Gas supply pipes shall be equal to or larger than 3/4" G boiler fittings. Prior to making the gas connection, a thorough internal cleaning shall be carried out to all fuel supply installation pipe furnishings as possible wastes may distort smooth operation and reliability of the boiler. Ensure that the gas supplied by the mains line is of the type prescribed for the boiler (refer to the label on the boiler).

Also, in case of reduced pressure, the network dynamic pressure (methane or LPG) used for supplying the combi should be carefully controlled and will impact the boiler strength. Ensure that gas valve connection is correct. Flammable gas supply pipe should be able to supply correct adequate gas amount to the boiler when the boiler is at full power and be projected and sized according to force and local gas company specification and instructions in order to guarantee the appliance efficiency. Connection system shall comply with the legislation in force.

2.1.6. Flammable Gas Quality

The boiler is designed to be used with pure fuel not containing any foreign substances; therefore, required filter systems must be available in the gas supply line (for ensuring purification of the fuel).

2.1.7. Heating and Domestic Hot Water Installations

Radiator and ground heating installation shall be configured in accordance with technical specifications of the TSE (Turkish Standards Institution) and MMO (Chamber of Mechanical Engineers), and according to the heat loss calculation. Radiator type and amount and ground heating installation pipe amount shall comply with the heat loss calculation.

- The design pressure strength of the heating installation shall be minimum 6 bar.
- If the mains pressure is more than 6.5 bar, a pressure reducer must be fitted.
- It is recommended to construct the radiator installation as double line and without using bends and joints as much as possible.
- Strainer filter shall be installed in heating return and tap water (city network) intake line if a boiler is to be used.

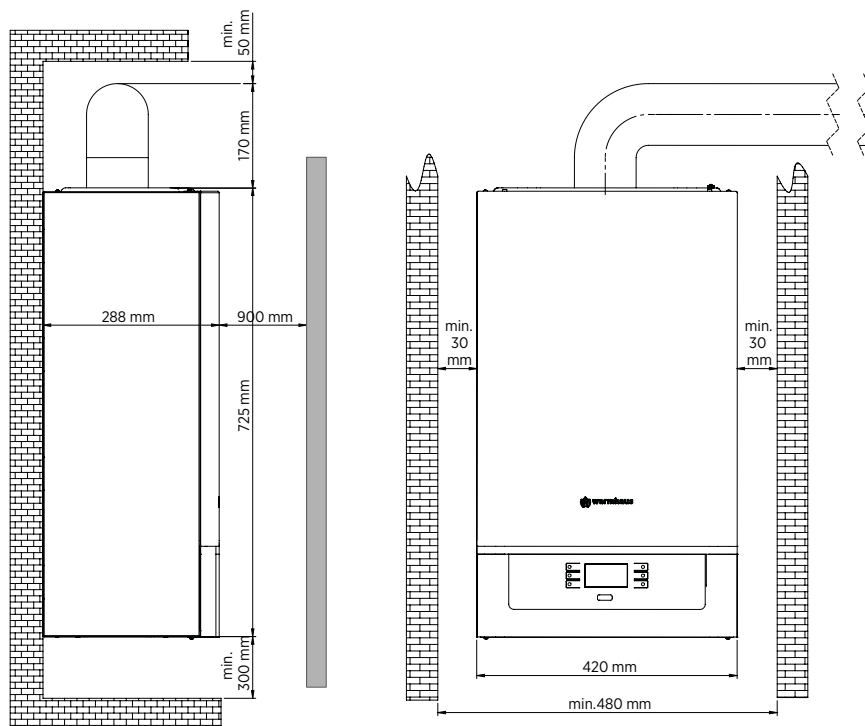

Figure 6 Boiler minimum dimensions in the cabinet *Minimum clearances required for servicing

SAMPLE INSTALLATION SCHEME

Single Boiler Scheme

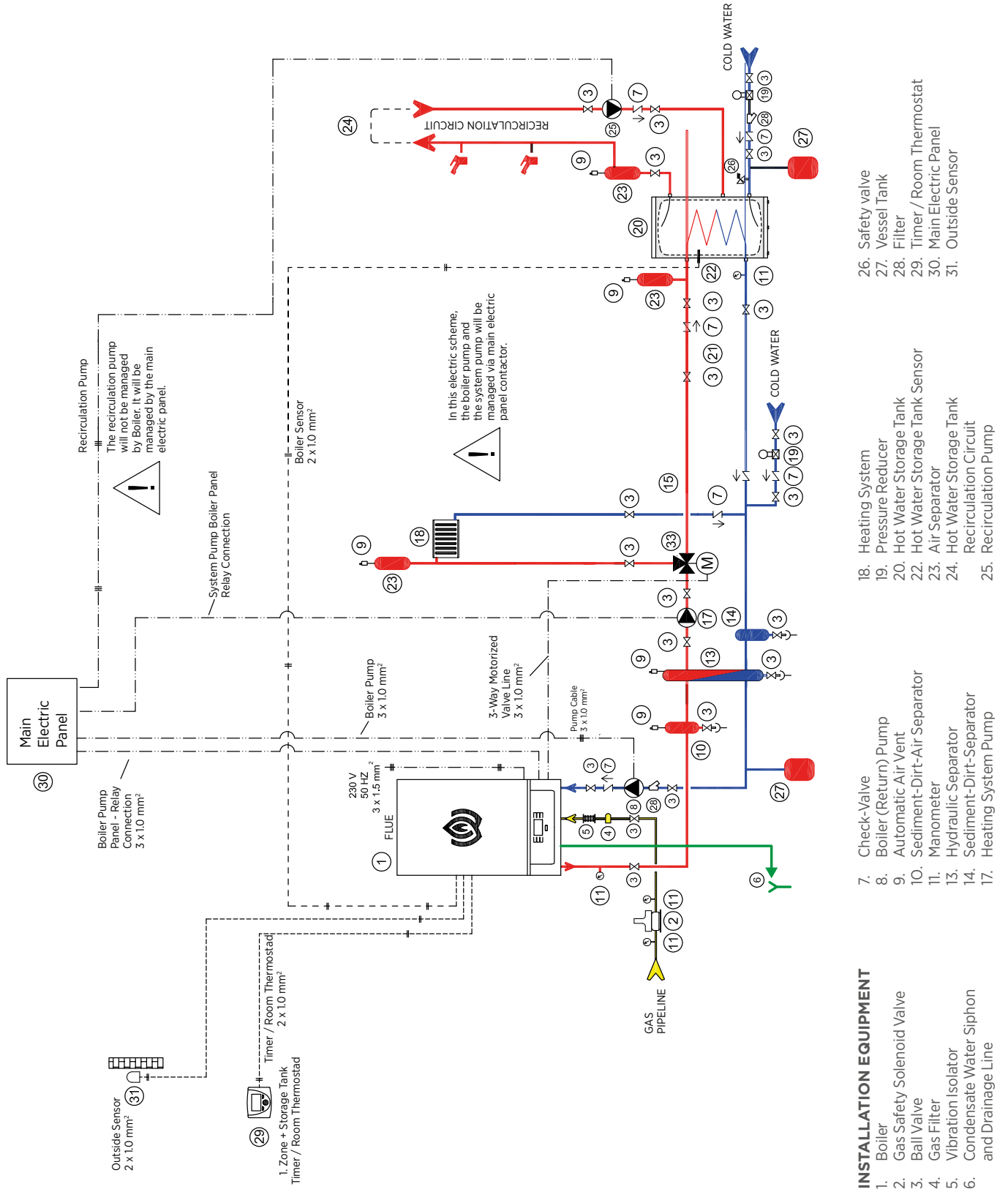

Figure 7 Enerwa Plus H Single Boiler with 1 High Temperature Zone + Hot Water Storage Tank System Scheme Example.



- An additional expansion tank with 50 liters capacity shall be used depending upon the volumetric capacity of the heating water of the heating circuit (closed circuit) and working temperature.
- If room thermostat and thermostatic radiator valve are to be used together; thermostatic valve shall not be installed in radiators in the place where room thermostat is present.
- Cross connection must be made for efficient functioning in radiators longer than 1,5 m.
- Covers shall be used for radiator and domestic hot water wall passages and fixed with wall clamps to prevent expansions due to heating.
- An external boiler shall be fitted to the boiler for supply of domestic hot water. In case of using domestic water boiler, the three-way valve and boiler sensor within the product accessories.
- The heating installation must be washed and cleared off dirt before filling!

2.1.8. Filling the flusher for Condensation Line

After the wall mounting operation of condensing boiler, electrical connections, radiator lines, hot tap water connections and condensation water drainage line are completed, condensation flusher shall be filled with water (Figure 8).

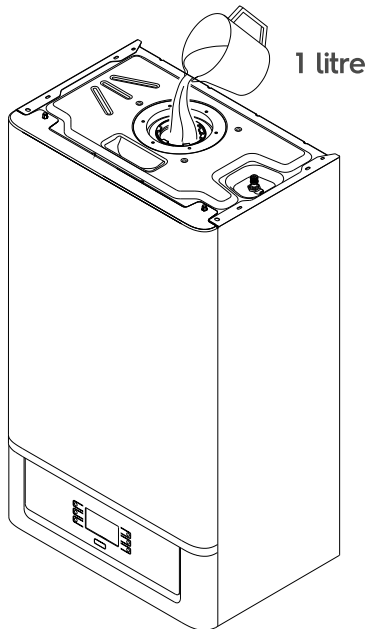



Figure 8 Filling the condensation flusher

 Leak-tightness of the drainage connection of the condensation line shall be ensured. However, pour approximately 1-liter water into the internal flue prior to fitting the flue bend of the flusher in the boiler against the gas leak risk during start-up. Thus, exhaust gas leakage will be prevented thanks to the water in the flusher.

Slope of the condensate water hose and line shall always be downwards

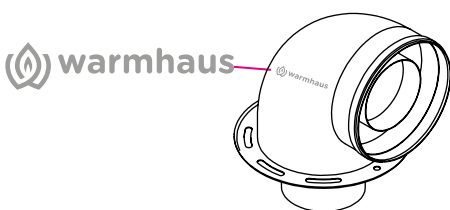





Figure 9 There is a Warmhaus logo on the flue bend.

2.1.9. Exhaust Gas Flue Pipe Set and Accessories Connection

 Flue accessory sets to be used in exhaust gas installation of hermetic boilers shall be original Warmhaus flue sets and they shall be used by observing measurements and restrictions given in installation instructions.

 In case of using exhaust gas pipe and/or accessories other than Warmhaus original exhaust gas flue pipes and accessories, boiler shall not be commissioned by the Authorized Service and thus, no warranty is provided!

The boiler shall only be installed with original Warmhaus air suction and exhaust gas discharge device made of plastic material.

Plastic channels cannot be installed without suitable protection against UV and weather conditions to distances over 40 cm and outdoors. Every pipe is defined with an explanatory and discriminative  Warmhaus mark mentioned in remarks.

IMPORTANT

When carrying out commissioning of the boiler, you are highly recommended to perform the following checks:

- Make sure that there are no liquids or inflammable materials in the immediate vicinity of the boiler.
- Make sure that the electrical connections have been made correctly and that the earth wire is connected to a good earthing system.
- Open the gas valve and check the soundness of the connections, including that of the burner to fan and burner hood to heat exchanger
- Make sure that the boiler is set for operation for the type of gas supplied.
- Check that the flue pipe for the outlet of the products of the combustion is unobstructed and has been properly installed.
- Make sure that any shutoff valves are open.
- Make sure that the system is charged with water and is thoroughly vented.
- Check that the circulating pump is not jammed.
- Purge the system, bleeding off the air present in the gas pipe by operating the pressure relief valve on the gas valve inlet.

2.1.10. Peripheral Distances of the Flue Outlet Connections

For positioning of the flue set outlet pipe, see Figure 16. The flue shall be installed in accordance with the national and local regulations.

No part of the outlet pipe or connections shall be blocked. If the outlet pipe passes 1000 mm nearby of a plastic or painted groove or 500 mm of painted fringes, an aluminum shield with at least 1000 mm length shall be placed below the groove or fringe. Outlet pipe shall be at least 2 m over surfaces within reach by individuals. Under certain weather conditions, outlet pipe may emit water vapor; installation shall not be performed at places where this vapor may cause discomfort.

Exhaust gases shall be prevented from entering flue ventilation spaces. Flue system of combi may be installed from inside the room without requiring intervention from the external wall. For that reason, an enclosure shall be installed in the wall for lining the internal surface of channel wherein the outlet pipe passes through the wall, particularly for thick walls.

2.1.11. Installation with (Ø80/125 mm) horizontal homocentric flue sets Connection of (Ø80/125 mm) horizontal homocentric flue set to the boiler

Since your boiler is a hermetic model, it takes the used air from outside and discharges exhaust gases created as the result of burning through the same flue group. In order to prevent emission of extremely harmful exhaust gases, flue usage and installation is very important, therefore warnings should be taken into consideration when flue connections are being performed.



→ Air
→ Exhaust Gas

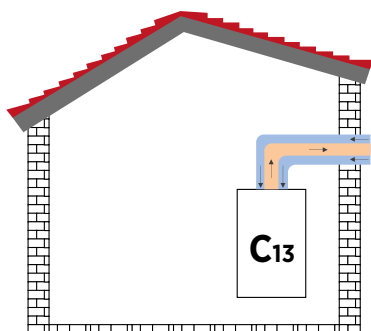

Discharge with homocentric flue connection

Figure 10 Hermetic (Concentric) and Flue (Split-Flue) type

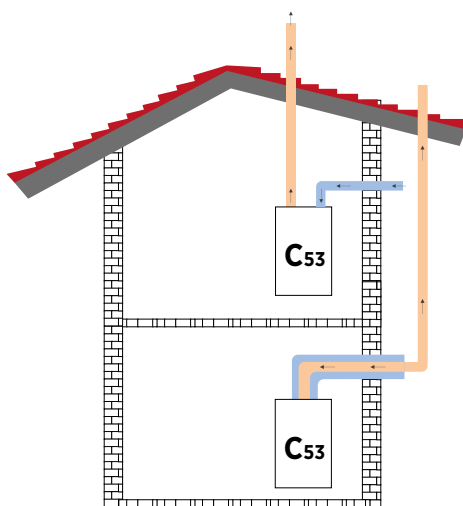

Exhaust gas discharge and fresh air intake with concentric flue kit and split flue kits

For room sealed appliances of the type C5 boilers

Attention: The terminals for the supply of combustion air and for the evacuation of combustion products shall not be installed on opposite walls of the building.

Figure 11 Hermetic concentric and vertical split flue connection.

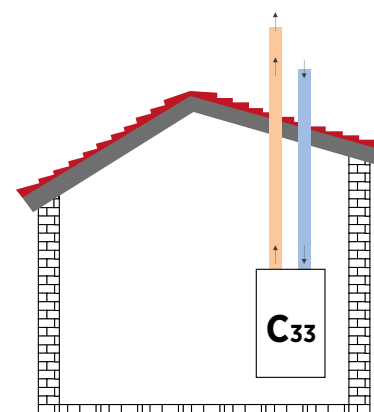

Exhaust Gas Discharge Fresh Air Intake with Split Flue Sets

Figure 12 Vertical Type Hermetic Use with Split Flue Set

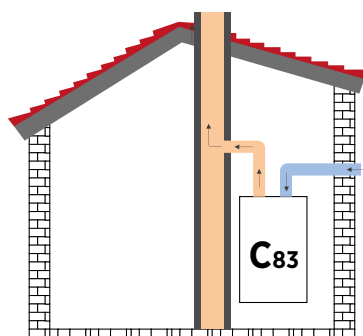

Discharge to building chimney and fresh air intake with split flue connection

For room sealed appliances of the type C8 boilers

- a) overheat combustion products temperature; <math>< 105\text{ C}^\circ</math>
- b) CO₂-content; 9.00 % (tolerance +0,5 / -0,5 %)
- c) characteristics of the chimney to which the boiler may be connected, according to fig 13.
- d) condensate flow into the appliance is not allowed.

Figure 13 Hermetic vertical split flue connection.

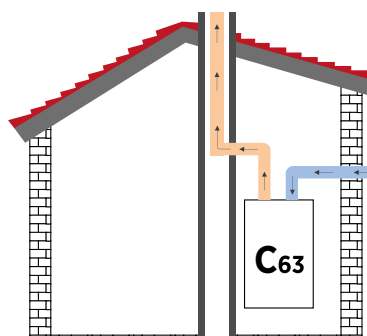

Exhaust gas discharge through the building chimney and fresh intake from outside with split flue sets

For room sealed appliances of the type C6 boilers

overheat combustion products temperature for flue; <math>< 105\text{ C}^\circ</math> CO₂ content at nominal operating conditions; 9.00 % (tolerance +0,5 / -0,5 %) maximum allowable draught and maximum allowable pressure difference between combustion air inlet and flue gas outlet (including wind pressures); 120 Pa. characteristics and the applications of the duct system to which the boiler can be connected; condensate flow into the appliance is not allowed. Maximum allowable temperature of combustion air; 40 C° maximum allowable recirculation rate of 10 % under wind conditions.

Attention: The terminals for the supply of combustion air and for the evacuation of combustion products shall not be installed on opposite walls of the building.

Figure 14 Building chimney connection with hermetic split flue

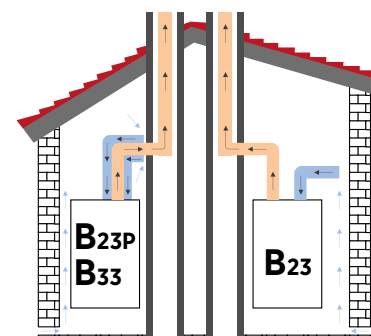

Exhaust gas discharge through the building chimney and fresh intake from outside with split flue sets

Figure 15 Use with split flue set

- Carry out required flue selection for the external flue connection. If the standard flue set is not adequate, please select most suitable components from our list of connection accessories considering warnings given in our user guide. Select the most suitable components by also considering our warnings.
- Fix the flange under the Bend piece (1) by using the Flange Bolt (10) Flange Connection Screws (11) to holes on the boiler. (10) secure it with Flange Connection Screws (11) onto the holes on the boiler.

- 2 impermeability bolts within the hermetic flue set (2) are placed into internal pipe slots at both ends of the 90° Bend.
- Place the exterior wall (EPDM) bolt into the flue terminal as seen in Figure 11a for grouping the flue outlet terminal. After placing the flue outlet terminal through exterior of wall and the previously drilled hole, fix the Interior Wall Connection Bolt (7) into the flue terminal. Place the other end of EPDM connection bolt installed on 90° flue bend of your boiler to the flue outlet. Ensure that sealings are placed properly:

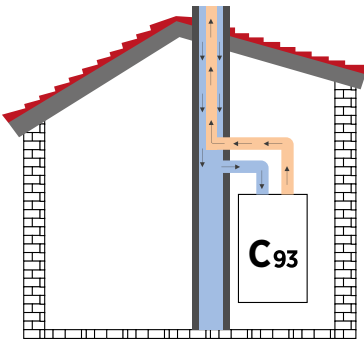

Attention: The minimum usable diameter must not be under 80 mm or equivalent for the vertical duct supplying the combustion air.

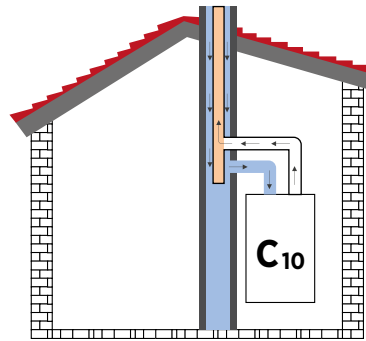

Attention:

- nominal working combustion product temperature : $> 70^{\circ}\text{C}$ max conditions
- overheat combustion products temperature : 105°C
- the minimum length of the specified connecting ducts; 1 mt / maximum length of the specified connecting ducts; 10 mt
- For size/shape of the end of the fitting please refer 2.2.14. Installation with Vertical Flue Sets page 13, Fig.26.
- Please re adjust TsP Paramater P22 = Flues gas pipe length (value 1 = 1 meter) according to actual flue length
- Its MUST to use NON RETURN valve ON the flue gas system.
- non-return valve function has to be checked annually by authorised service.

Information for the design of the common duct system for a type C(10) boiler

- The boiler is designed to become connected to a common duct system that is designed to operate where the static pressure in the common flue duct might exceed the static pressure in the common air duct by 25 Pa under the condition that n-1 boilers are running at maximum nominal heat input ($Q_{n,max}$) and 1 boiler at the minimum heat input allowed by the controls
- combustion product mass flow rate at maximum nominal heat input are given technical table.
- combustion product mass flow rate at minimum heat input allowed by the controls are given technical table.
- G20 : CO₂ or O₂ content of the combustion products at nominal operating conditions 9 % (+0,5/-0,5)
G30 / G31 : CO₂-content; 10,00 % (tolerance : +%0,5 / -0,5 %)
- minimum allowable pressure difference between combustion product outlet and air inlet shall be declared as -200 Pa (including -100 Pa wind pressure).

General for connection of a type C(10) boiler to a common duct system

Characteristics and the applications of the common duct system to which the boiler can be connected, with at least the following information:

- the flue duct system shall be CE marked and comply with EN 15502 standart 12.2.1.4.111.2;
- nominal combustion products temperature for dimensioning the common duct system shall be declared as 25°C ;
- the combustion product mass flow rate at maximum heat input shall be specified for every connection point; the terminal of the common duct shall be designed to induce a draft;
- condensate flow into the boiler is allowed;
- maximum allowable recirculation rate of 10 % under wind conditions;
- the maximum allowable pressure difference between combustion product inlet and air outlet of the common duct system shall not be exceeded when n-1 boilers are running at maximum nominal heat input ($Q_{n,max}$) and 1 boiler at the minimum heat input allowed by the controls;
- the common flue duct shall be appropriate for an overpressure of at least 200 Pa;
- the duct system shall not include a draft diverter.

Warning: the boiler if it is installed as a C (10) boiler and IF / when the boiler is disconnected the air outlet and the combustion product inlet openings shall be closed and checked on tightness.

Figure 16 Exhaust gas discharge through the building chimney and fresh intake from the building chimney with split flue sets

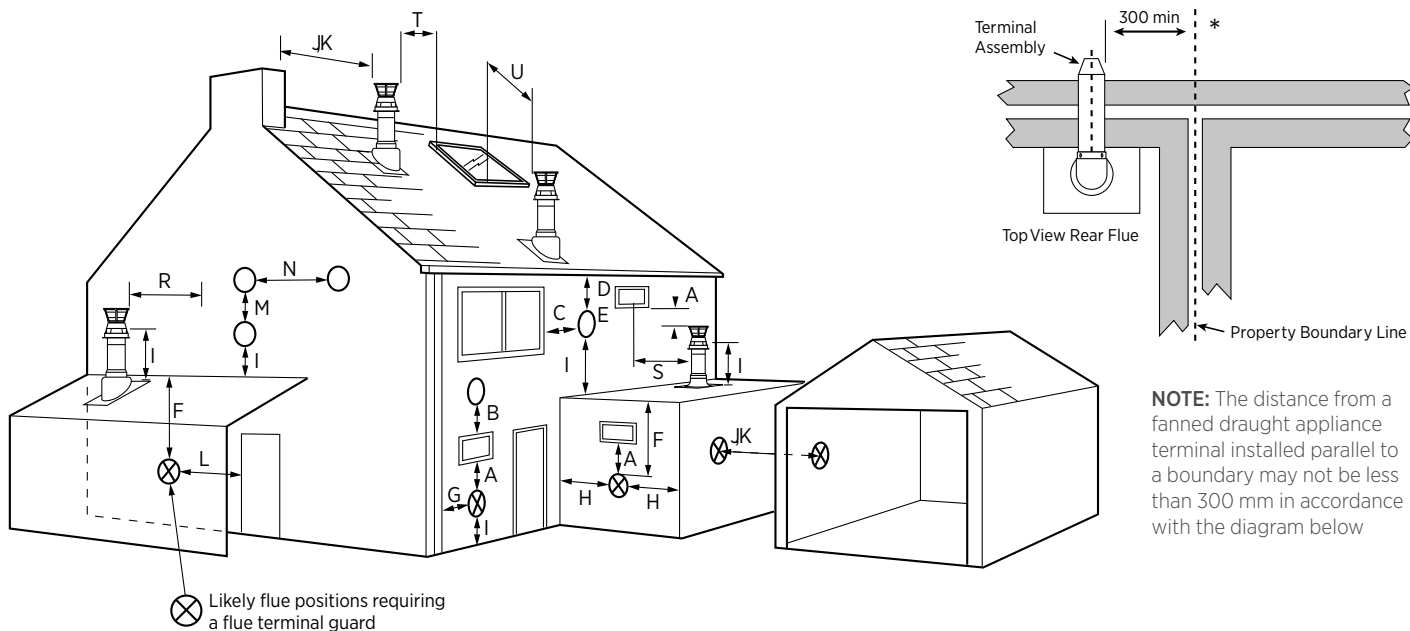

Figure 17 Environmental locations of flue

	Terminal Position with Minimum Distance	(mm)
A ¹	Directly below an opening, air brick, opening windows, etc.	300
B ¹	Above an opening, air brick, opening window etc.	300
C ¹	Horizontally to an opening, air brick, opening window etc.	300
D ²	Below gutters, soil pipes or drain pipes.	25 (75)
E ²	Below eaves.	25 (200)
F ²	Below balconies or car port roof.	25 (200)
G ²	From a vertical drain pipe or soil pipe.	25 (150)
H ²	From an internal or external corner.	25 (300)
I	Above ground, roof or balcony level.	300
J	From a surface or boundary line facing a terminal.	600

	Terminal Position with Minimum Distance	(mm)
K	From a terminal facing a terminal (Horizontal flue). From a terminal facing a terminal (Vertical flue).	1200 600
L	From an opening in carport (e.g. door, window) into the dwelling.	1200
M	Vertically from a terminal on the same wall.	1500
N	Horizontally from a terminal on the same wall.	300
R	From adjacent wall to flue (vertical only).	300
S	From an adjacent opening window (vertical only).	1000
T	Adjacent to windows or openings on pitched and flat roofs	600
U	Below windows or openings on pitched roofs	2000

1 In addition, the terminal should be no nearer than 150 mm to an opening in the building fabric formed for the purpose of accommodating a built-in element such as a window frame.
2 Only ONE 25mm clearance is allowed per installation. If one of the dimensions D, E, F, G or H is 25mm then the remainder MUST be as shown in brackets, in accordance with B.S.5440-1.

VENTILATION

Enerwa Plus H boilers can be installed in boiler rooms whose size and requirements meet current regulations. The following is provided for your guidance only, and assumes the ventilation air is taken directly from outside.

The sizes of the vents may need to be increased in respect of other appliances installed in the same area, and seasonal use. Take care that the position of low level vents would not be subject to adverse weather conditions, i.e. flooding. Ventilation requirements for Enerwa Plus H boilers and cascade systems. BS6644 has a requirement that the temperatures in a room or compartment do not exceed certain levels:

- +25°C at floor level (0-100 mm)
- +32°C at mid level (1.5 m above the floor level)
- +40°C at ceiling level (0-100 mm from ceiling)

When installed as a class B appliance (open flued, not room sealed).
Installed in a room High level (within 15% of the room height from ceiling) - 2 cm²/kW of net heat input.

Low level (low as possible within 1 meter from floor natural gas) - 4 cm²/kW of net heat input a single Enerwa Plus H boiler would require (36

cm²/1800 H; 50 cm²/2500 H; 60 cm²/3000 H; 70 cm²/3500 H) at high level and (72 cm²/1800 H; 100 cm²/2500 H; 120 cm²/3000 H; 140 cm²/3500 H) at low level.

Installed in a compartment or enclosure High level (within 15% of the room height from ceiling) - 5 cm²/kW of net heat input Low level (low as possible within 1 meter from floor natural gas) - 10 cm²/kW of net heat input.

A single Enerwa Plus H (23.7 kW; 28 kW; 33.02 kW net input) boiler would require (90 cm²/1800 H; 125 cm²/2500 H; 150 cm²/3000 H; 175 cm²/3500 H) at high level and (180 cm²/1800 H; 250 cm²/2500 H; 300 cm²/3000 H; 350 cm²/3500 H) at low level.

When installed as a class C appliance (room sealed). Installed in a room High level (within 15% of the room height from ceiling) - 2 cm²/kW of net heat input Low level (low as possible within 1 meter from floor natural gas) - 2 cm²/kW of net heat input A single Enerwa Plus H (23.7 kW; 28 kW; 33.02 kW net input) boiler would require (36 cm²/1800 H; 50 cm²/2500 H; 60 cm²/3000 H; 70 cm²/3500 H) at high level and (36 cm²/1800 H; 50 cm²/2500 H; 60 cm²/3000 H; 70 cm²/3500 H) at low level.

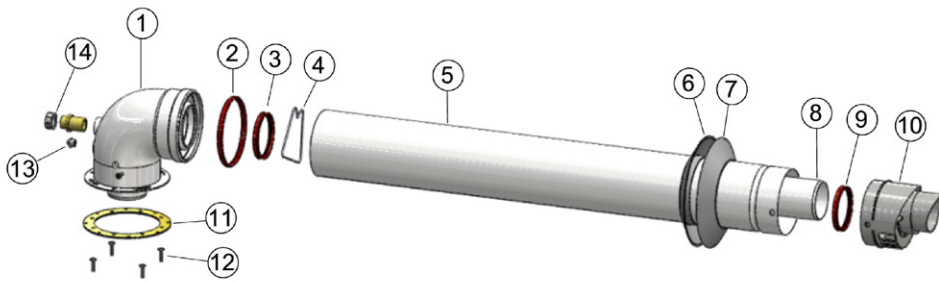

1. 90° bend
2. Sealing ring
3. Sealing ring
4. Centering wire
5. External flue pipe
6. Inner wall flange
7. Outer wall flange
8. External flue pipe
9. 60 Sealing ring
10. Protection grid
11. Flange gasket
12. Flange connection screws
13. Check measurement plug
14. Fresh air inspection cover

Figure 18 Ø 80/125 mm Concentric Flue Set

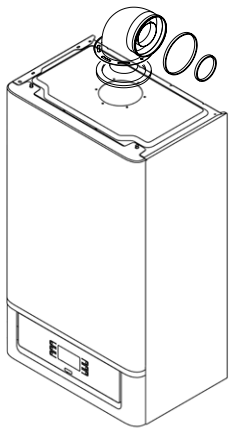

Figure 19 Vertical flue set installation

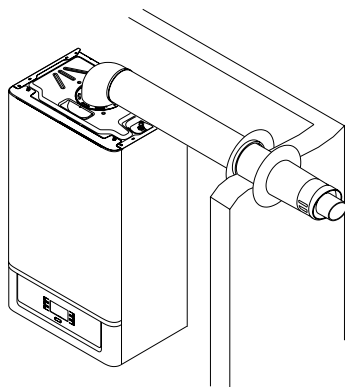

Figure 20 Boiler concentric wall outlet for hermetic use

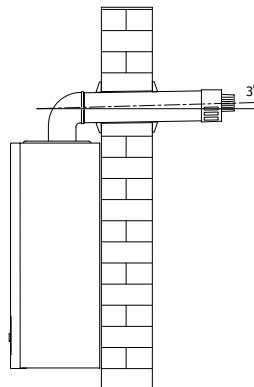
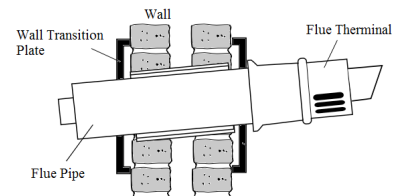

Figure 21 Condensing boiler flue slope



Click-fit gasket for concentric extension pipes and bends. For joining any extensions of exhaust gas flows to other components of the flues: Install a gasket on the grooved (female) side of the previous part from the flat side of the concentric pipe or concentric bend, in this case make sure that you installed the washer, thus tightness and integrity of the parts of set will be ensured.

! When it is required to shorten the discharge flue and/or extension, consider that internal pipe should protrude 5 mm when compared with the external pipe.

! For safety purposes, boiler suction / discharge flue shall not be blocked even temporarily.

! During installation of horizontal pipes, pipe slope shall be minimum 3% upwards, and the pipe shall be secured with dowels and bracelets with 3-meter intervals.

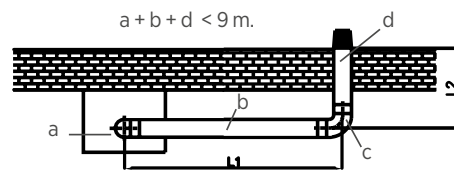

- a- Horizontal Flue Set Bend (90°)
- b- Flue Extension Pipe
- c- Additional 90° Bend
- d- Horizontal Flue Set Pipe

Figure 22 II. Example of flue installation with one 90° bend

! Total length of concentric flue set shall not exceed 10 m with single bend horizontally. Also, this total length reduces by 1 m with every 90° bends or two 45° bends. Maximum 3 pieces of 90° bend can be used.

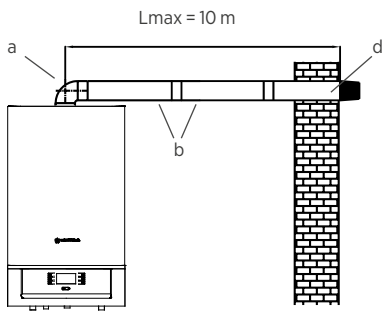

Figure 23 I. Example of flue installation with one 90° bend

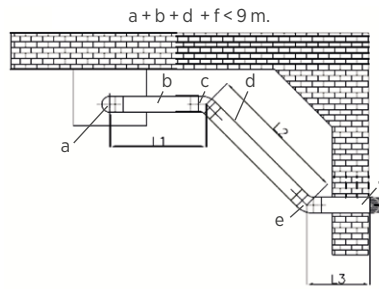

Figure 24 III. Example of flue installation with one 90° bend and two 45° bends

- a- Horizontal Flue Set Bend (90°)
- b- Flue Extension Pipe
- c- Additional 45° Bend
- d- Standard Flue Set Pipe-Additional 45° Bend
- f- Horizontal Flue Set Pipe

2.1.12. Installation with Vertical Concentric Flue Sets

Your boiler can also be vertically connected to flat and sloping roofs via available connection accessories depending on the status of installation place. For direct connections, it shall not exceed 11m with (Ø 80/125 mm) vertical flue set.

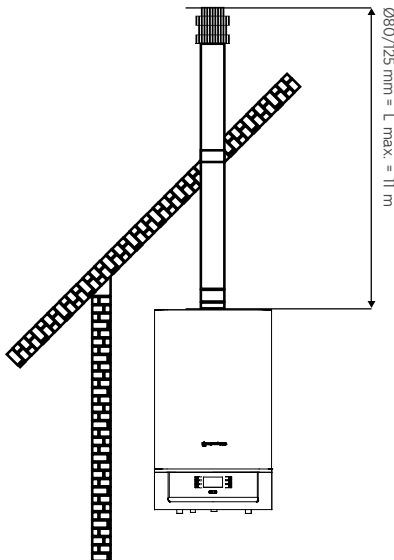
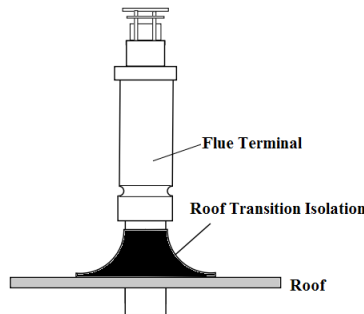
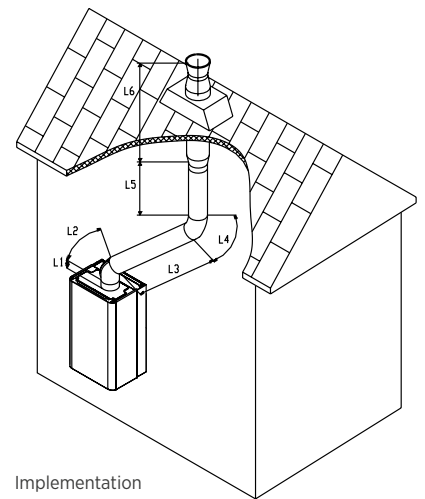

Figure 25 Vertical flue set installation



ATTENTION!
For C3 boilers the terminal outlets from separate combustion and air supply circuits shall fit inside a square of 50 cm and that the distance between the planes of the two orifices shall be less than 50 cm.



Implementation

L1	=0.3 m.	
L2	=0.5 m. (45° bend equivalent length)	
L3	=2.0 m.	
L4	=0.5 m. (45° bend equivalent length)	
L5	=1.0 m.	
L6	=2.0 m.	
<hr/>		
L Total	=6.3 m.	6.3 m. < Lmax = 11 m.

It is correct in implementation.

Figure 26 Vertical flue set installation

2.1.13. Use of Split Flue Type (Hermetic)

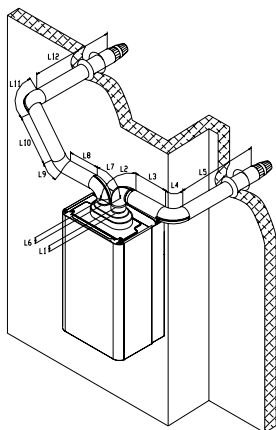

Implementation

L1	=0.5 m.	
L2	=1.0 m. (90° bend equivalent length)	
L3	=1.5 m.	
L4	=1.0 m. (90° bend equivalent length)	
L5	=1.5 m.	
L6	=0.5 m.	
L7	=1.0 m. (90° bend equivalent length)	
L8	=0.5 m.	
L9	=0.5 m. (45° bend equivalent length)	
L10	=1.5 m.	
L11	=1.0 m. (90° bend equivalent length)	
L12	=1.5 m.	
<hr/>		
L Total	=12 m.	12 m. < Lmax = 30 m.

It is correct in implementation.

ATTENTION!
For C1 boilers the terminal outlet from separate combustion and air supply circuits shall fit inside a square of 50 cm for boilers with a heat input up to 70 kW

Figure 27 Example of Split Flue (Hermetic) Type

Concentric Flue Systems For Condensing Boilers (Ø60/100 mm)

	Product Name	Product Code
	(Ø60/100) Condensed Concentric Horizontal Flue Set	153.11.014.000002
	(Ø60-100) Condensed Vertical Flue Set with Adapter L=1533	153.11.660.600013
	(Ø60/100) Condensed Flue Extension L=500 mm	153.11.660.600014
	(Ø60/100) Condensed Flue Extension L=1000 mm	153.11.660.600015
	(Ø60/100) Condensed Flue Extension L=2000 mm	153.11.660.600016
	(Ø60/100) Condensed 45° Elbow	153.11.660.600017
	(Ø60/100) Condensed 90° Elbow L=170 mm	153.11.660.600018
	(Ø60/100) Condensed Vertical Adapter L=130 mm	153.11.660.600019

Stand-Off Kit

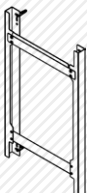
	Product Name	Product Code
	Stand-Off Kit	151.11.04.003



Twin Flue Kits For Condensing Boilers (Ø80/Ø80 mm)

153.11.660.600096 Ø80 İkiz Baca Seti

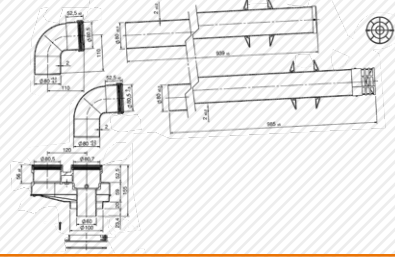

153.11.660.600102 Ø 60- Ø 80 İkiz Baca Adaptörü

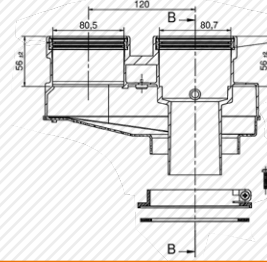

153.11.660.600091 Ø80 Yoğ. Uzatma Tek Cidar 500mm



153.11.660.600092 Ø80 Yoğ. Uzatma Tek Cidar 1000mm

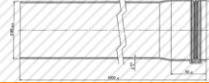

153.11.660.600093 Ø80 Yoğ. Uzatma Tek Cidar 2000mm



153.11.660.600094 Ø80 90° PP Dirsek Tek Cidar

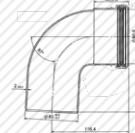

153.11.660.600095 Ø80 45° PP Dirsek Tek Cidar

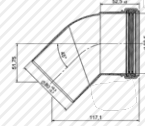

153.11.660.600099 Ø80 İç Duvar Baca Bileziği

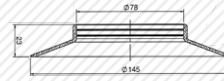

153.11.660.600098 Ø80 Dış Duvar Baca Bileziği

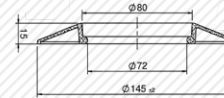

153.11.660.600100 Ø80 Kondens Kapanlı Dik Baca Çıkış Adaptörü

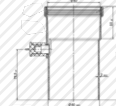



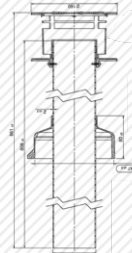



153.11.660.600097 Ø80 Dik Baca Çıkış Terminali Seti

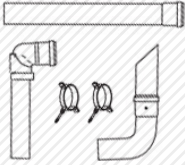

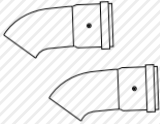

Plume Displacement Kits Ø60 mm

	Product Name	Specification	Product Code
	Plume Displacement Terminal Kit	With 1 m Extension and Two Brackets	153.11.660.6000 31
	Plume Displacement Kit Bend	90°	153.11.660.6000 32
	Plume Displacement Kit Bend	45°	153.11.660.6000 33
	Plume Terminal		153.11.660.6000 34
	Clamp Pack		153.11.660.6000 35
	Plume Displacement Kit Extension and Brackets	1000 mm	153.11.660.6000 36

2.1.14. Installation at Partially Protected Outsid

Installation Instructions: This combi can be installed in partially protected outsid Partially protected area means the place where the boiler will not be directly exposed to atmospheric factors and weather conditions (rain, snow, etc.)

Frost Protection: The boiler is equipped with a system that prevents frost by automatically activating the pump and boiler when the internal water is lower than 5°C.

Frost protection function only depends on below given conditions:

- If the combi is correctly connected to gas and electrical sources;
- If the combi is supplied from gas and electricity sources in a fixed way;
- If the Combi is not in failure situation due to lack of ignition;
- If radiator installation pressure is full and radiator valves are open;

The boiler is protected against frost up to -5°C ambient temperature.

Lowest Temperature -5°C. In case the boiler is installed in an environment with a temperature lower than -5°C, and gas supply is interrupted or passed into failure due to failing to make ignition, Frost Prevention System

shall not be activated and frost/failure shall occur in the device. Following instructions should be followed for preventing the risk of frost:

- Heating circuit, into antifreeze (special heating devices) a good brand of antifreeze manufacturer's instructions are followed carefully so as it deems necessary for the rate and the minimum temperature is desired to be stored in the heater frost protection with the matter.

Materials used for manufacturing the combi are resistant against glycol and propylene based anti-frost liquids. Follow warnings of supplier company regarding their technical service life and possible disposals.

Frost / icing protection of the combi is guaranteed only under these conditions:

Any damages caused by noncompliance to the terms specified above and power loss are excluded from warranty.

If the boiler is installed in places where temperature drops below 0°C (both for hot domestic water and heating purposes), pipes of the heating system and domestic water installation must be insulated.





2.1.15. Electrical Connections

Ensure electrical safety of boiler by connecting to an effective earthing installation that follows safety instructions in force. Earthing shall not be performed through the neutral line on the socket in places without earthing! It is dangerous and unacceptable to use gas and water connection pipes for earthing.

WARMHAUS A.Ş. cannot be held responsible for any damage or loss to individuals or property arising from failing to provide earth connection of the boiler and not being fitted by a competent Electrician or registered individual in accordance with directives and standards in force in the country where the boiler is installed.

Also, ensure that the electricity installation complies with the maximum power to be supplied as indicated in technical specifications label. boiler shall be energized with "X" type socketless special power supply cables. "Warmhaus boiler has an IPX5D protection level. Power supply cable should be connected to 230 V +%10; -%15 50Hz grid with L-N poles and relying on the earth connection, high voltage category 3rd class multiple poled disconnected should be envisaged on the same grid. Contact our Authorized Warmhaus Service for replacement of the cable.

 The power supply cable must follow the specified route. In case of replacing fuses on the board, use 2A or 3,15A quick type fuse. In order to feed the device from the mains, adapter, multiple sockets and extension cables are not permitted.

 Room thermostat, outside Temperature Sensor, etc. control devices are provided as optional accessories for Warmhaus boiler devices and they must be Warmhaus approved.

Please follow instructions of use for placement of outside Temperature Sensor.

This sensor can be directly connected to electrical installation of the boiler, and it automatically reduces the maximum return water temperature in the installation when outside temperature rises for enabling functioning according to outside temperature changes sent to radiator installation outside Temperature Sensor is activated when connected as independent from the used room thermostat typology and functions together with room thermostats. The relation between installation input temperature and outside temperature is defined according to curves in the diagram from position of the button located on the panel of boiler (or on the control panel if connected to boiler (Figure 29).

Electrical connection of the Outside weather temperature Sensor shall be made to the terminals to which the White & White cables of the Aux cable connected to the electronic card of the boiler are connected (Figure 28).

2.1.16. Optional Controls: Room Thermostat, Outside Temperature Sensor, Connections and Installation

Room thermostat, Outside Sensor, etc. control devices must be connected to Warmhaus boiler devices by the authorized service personnel; In case connections are performed by unauthorized persons, boiler warranty shall be void.

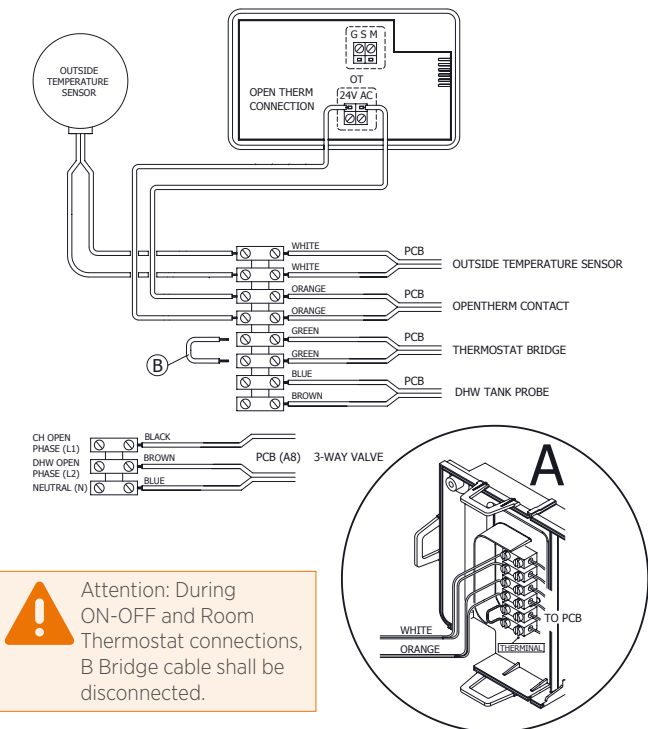



Figure 28 Connection of room thermostat and Outside Sensor to boiler terminal group.



Instruction for Installation: Installation of the appliance shall be carried out only by Warmhaus Authorized Service. The dual cable required for installation shall be provided by the dealer/customer.

 Room thermostat shall be mounted 1,25 to 1,5 m above the ground.

 It shall be minimum 30 cm away from any doors or windows allowing airflows.

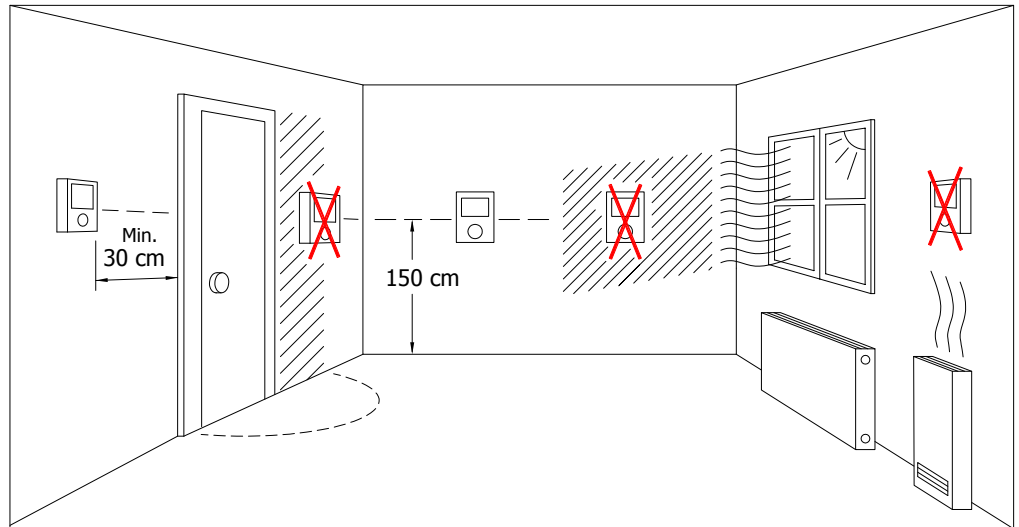



Figure 29 Position of thermostat

2.2. HYDRAULIC INSTALLATION RULES

2.2.1. Heating System Water

 In order to prevent invalidity of appliance warranty prior to making boiler connections, clean possible residues found in main heat exchangers (pipes, heater assembly, etc.) with dissolvent or equal substances, otherwise they will negatively affect functioning of the boiler. Equivalent materials in order to avoid cancellation of the warranty, otherwise proper operation of the boiler will be affected negatively. In order to prevent lime scale in the radiator follow rules envisaged by standards regarding domestic hot water and radiator installations.

2.2.2. Filling/Draining the Heating System

After completing installation of the boiler, a ball valve shall be fitted to the heating system to provide supply from the city line to the closed circuit heating system. Open this valve until the Manometer pressure reaches 1-1.5 bar, then close the Filling Valve by turning it clockwise, and Vent the air in the radiator with air vent valves.

The discharge of the safety valve of the boiler must be connected to a discharge hopper. Otherwise, the manufacturer shall not be responsible for drainage of water into to the installation place when the safety valve is enabled.

2.2.3. Drainage of the Condensate Water

The appliance shall be connected to the drainage water network through pipes with minimum $\varnothing 24$ mm diameter, and resistant to acidic condensate water. The connection of the appliance to the drainage water line shall be performed in the way to prevent freezing of the water contained therein. It must be ensured before starting up the appliance that the condensate water has been drained properly; then check that the flusher is filled with condensation water (2.2.9). In addition, the installation and all connections must comply with the specifications, national and local regulations on discharge of waste water.

2.2.4. Circulation Pump (Optional)

As Enerwa Plus H boilers are supplied without pump, a pump shall be used to provide the required flow rate for the radiator heating system depending on the critical line pressure loss. Warmhaus recommends the pump complying with the European Energy Efficiency Directives (ErP) given in Figure 38 which is provided as optional, in order to achieve a good performance and energy saving

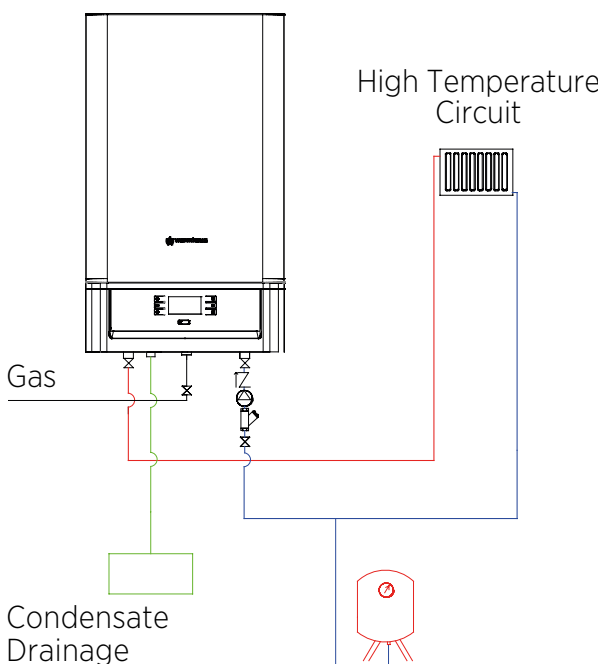

Figure 30 Connection Diagram of Single Boiler and 1 High Temperature Circuit

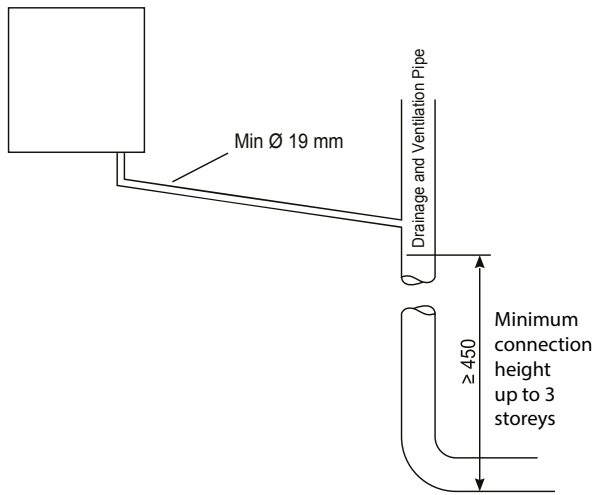

Figure 31 Connection of the Condensate Water Drainage Pipe to Internal Drainage and Ventilation Pipe

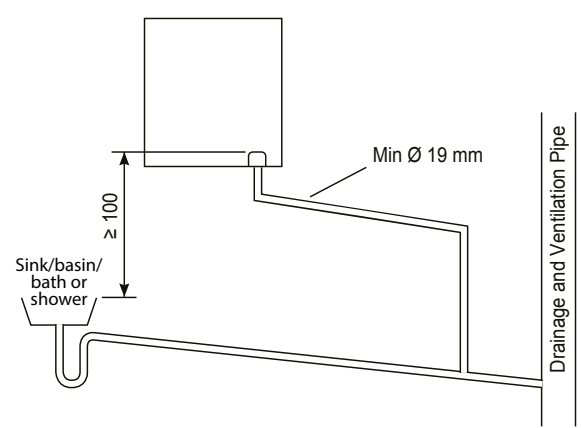

Figure 32 Connection of Condensate Water Drainage Pipe at Indoor Bathroom Drainage Lower Level

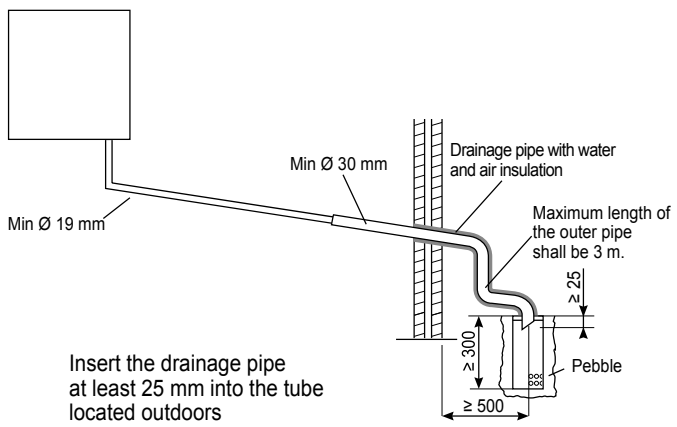

Figure 33 Outside Connection of Condensate Water Drainage Pipe

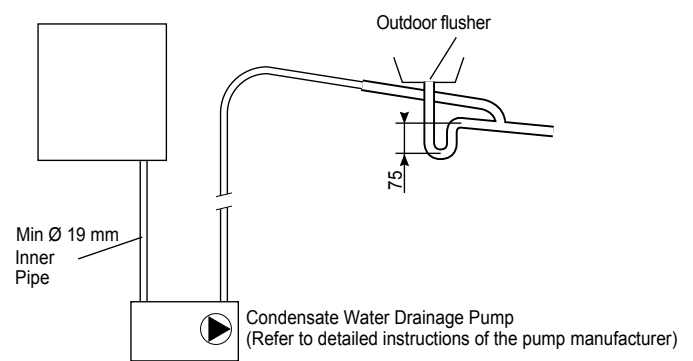

Figure 34 Typical Connection Method of a Condensate Water Drainage Pipe (refer to detailed instructions of the pump manufacturer)

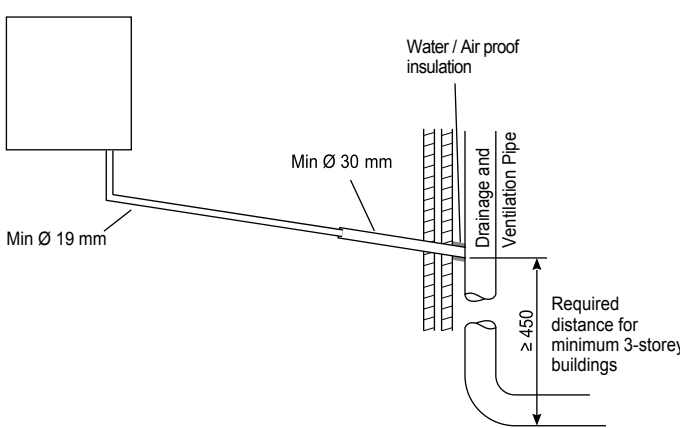

Figure 35 Connection of Condensate Drainage to Drainage and Ventilation Pipe

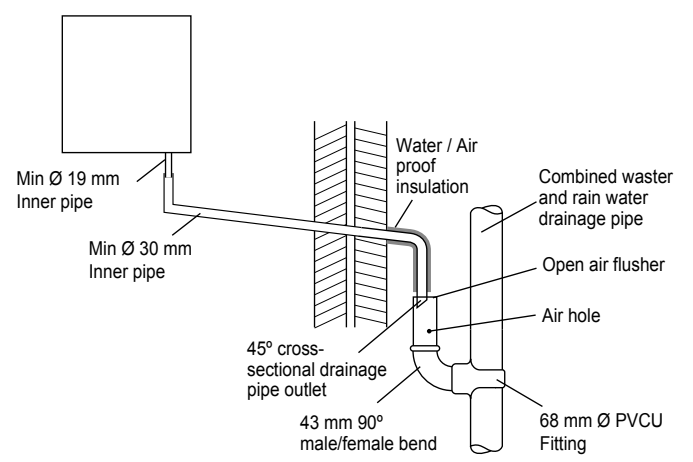

Figure 36 Connection of Condensate Drainage to Rain Water Drainage

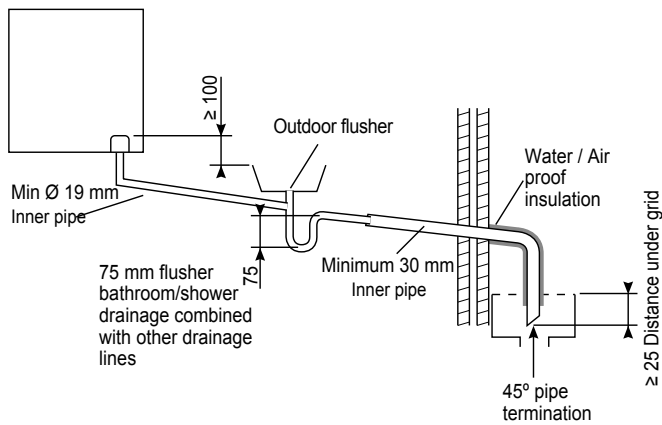

Figure 37 Connection of Condensate Drainage to Rain Drainage Line through Sink, Bathtub or Shower Drainage Pipe

2.2.5. Checks for Start-up of the Boiler

Start-up of the boiler must be carried out by Warmhaus Authorized Service in order to commence warranty of the boiler. Preliminary preparations shall have been performed prior to request for authorized service appointment.

- Gas supply approval certificate shall have been obtained from your local gas

2.3.1. The Boiler Pumps

Enerwa and Enerwa Plus H boilers are equipped with frequency converters and automatic air vent.



GRUNDFOS UPM3 15-70 CAOD AA

CE MARK COMFORMITY WITH FOLLOWING RELEVANT EC DIRECTIVES	EMC Directive (2004/108/EC), Low voltage Directive (2006/125/EC) Ecodesign Directive (2009/125/EC)
Power	Grundfos UPM3 15-70 CAOD AA
Energy Efficiency Index (EEI) (EN16297/3)	≤ 0,20
Max. delivery head in [m] at Q = 0,25 m ³ /h	6,90 m
Max. volume flow (H: 1,11 m)	2,5 m ³ /h
Max power consumption	52
Max. speed	5766 rpm

Hydraulic operational areas

ENERWA PLUS 2500 H

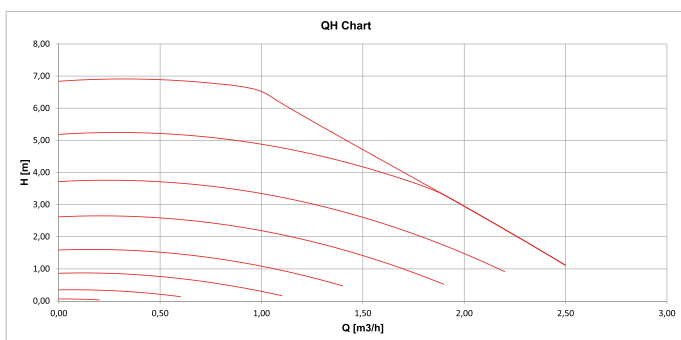

ENERWA PLUS 3000 H ENERWA PLUS 3500 H

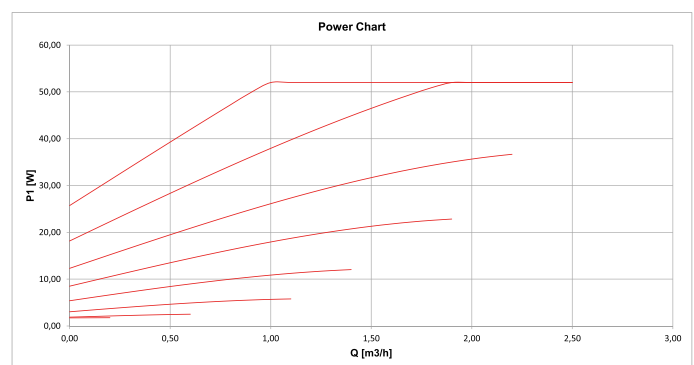

Figure 38 Pressure, flow and electricity consumption of pumps according to power capacities of boilers

authority for your gas line.

- The connection of the boiler by using 2 or 3 ampere fuse must be in place.
- Make sure that there is no electricity power loss in your house.
- Make sure that there is no city water cuts in your house.
- Ensure that water is supplied to the heating system and the boiler manometer shows 1,2-1,5 bar pressure

2.3. FITTINGS REQUIRED FOR OPERATION OF THE BOILER AND HEATING SYSTEM

For single or cascade use of the condensing boiler, the heating system shall be fitted with the fittings specified below.

- A hydraulic separator shall be used for ideal thermal and pressure distribution of the boiler and system, and an exchanger with plate shall be used if the system-side pressure is higher than the maximum pressure of boiler and/or oxygen barrier pipe is not used on the system side.
- Air Separator
- Mud/Debris Strainer
- Expansion Tank (If the system is separated by a plate exchanger, at least one expansion tank must be placed in the return line of the cascade side and the return line of the heating system side.)
- Filter elements (strainers) must be fitted to return line of each boiler. These fittings which ensure efficient operation of your heating system and provide longer technical life, are obligatory accessories for warranty of your appliance. These accessories are not supplied with the boiler.

2.4. SAMPLE INSTALLATION SCHEME

Cascade System Scheme

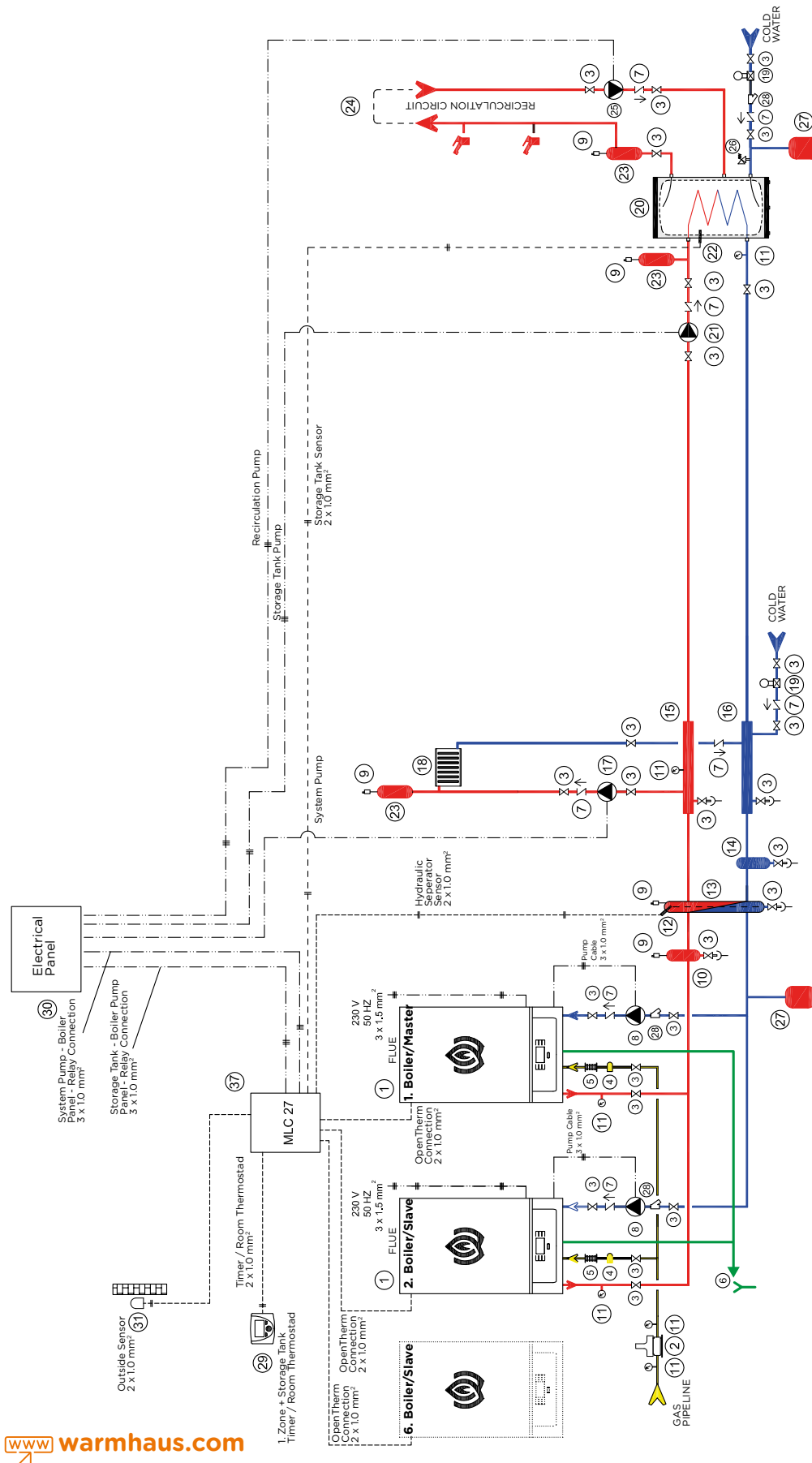

- INSTALLATION EQUIPMENT**
- Boiler
 - Gas Safety Solenoid Valve
 - Ball Valve
 - Gas Filter
 - Vibration Isolator
 - Condensate Water Siphon and Drainage Line
 - Check-Valve
 - Boiler (Return) Pump
 - Automatic Air Vent
 - Sediment-Dirt-Air Separator
 - Manometer
 - Hydraulic Separator
 - Sediment-Dirt-Separator
 - Heating System Flow Collector
 - Heating System Return Collector
 - Heating System Pump
 - Pressure Reducer
 - Hot Water Storage Tank
 - Hot Water Storage Tank Pump
 - Hot Water Storage Tank Sensor
 - Air Separator
 - Hot Water Storage Tank
 - Recirculation Circuit
 - Recirculation Pump
 - Safety valve
 - Vessel Tank
 - Filter
 - Timer / Room Thermostat
 - Main Electric Panel
 - Outside Sensor
 - MLC 27 Cascade Module

Figure 39 Cascade System with Enerwa Plus H Boilers and 1 Radiator (High Temperature) Circuit and Hot Water Storage Tank Scheme Example

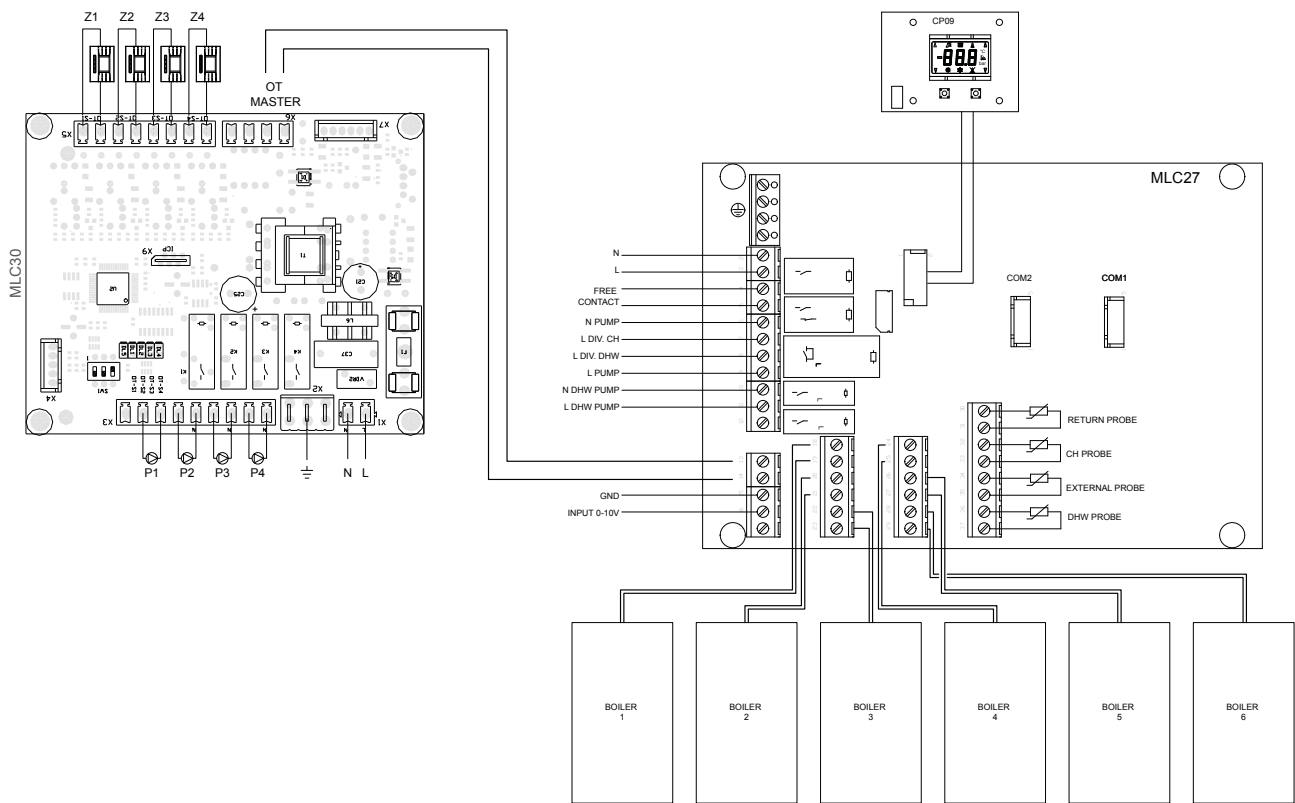

Figure 40 MLC 27 and MLC30 Electrical Connection Diagram for Enerwa Plus H with Cascade System and 4 High Temperature (Radiator) Zone System

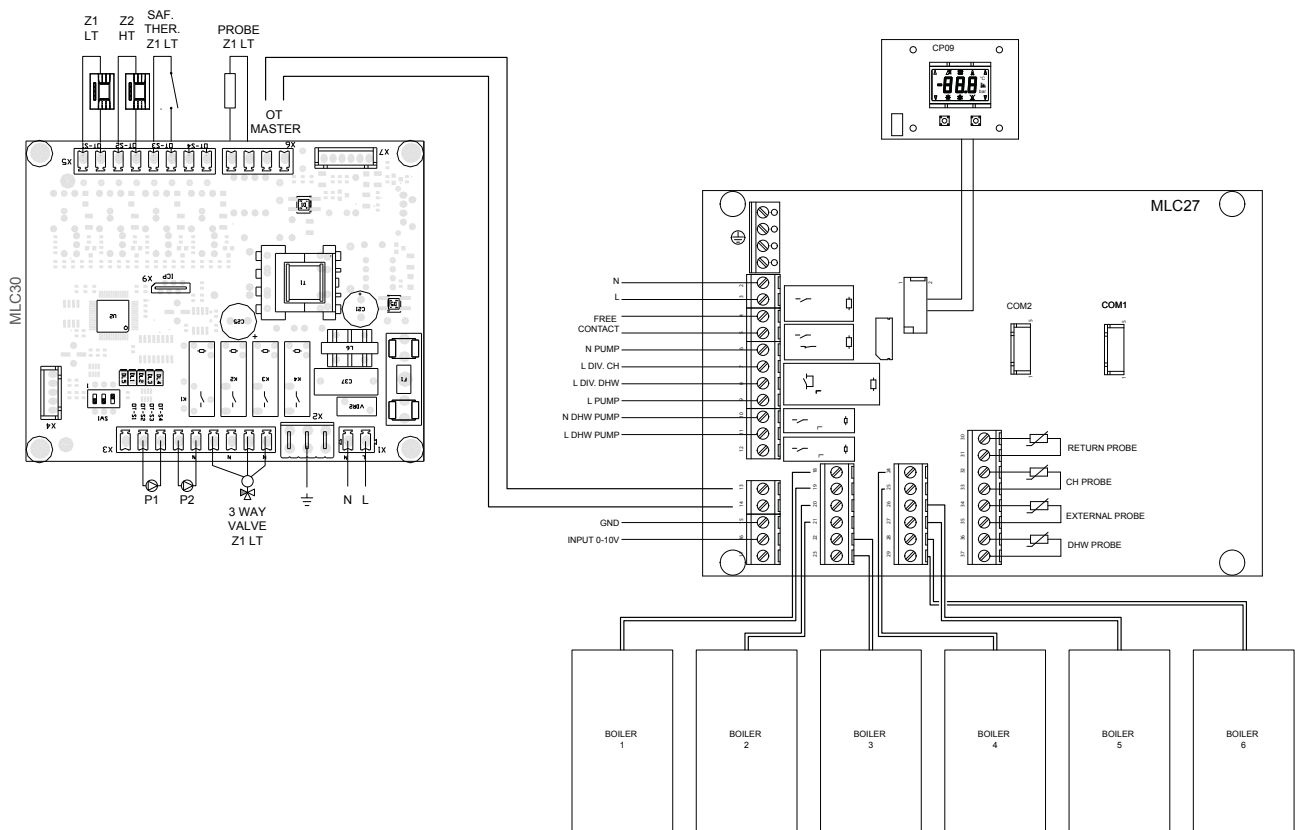





Figure 41 MLC 27 and MLC30 Electrical Connection Diagram for Enerwa Plus H Boilers with Cascade System and 1 Low Temperature (Underfloor Heating) Zone System







REMOTE CONTROL & CONTROL ACCESSORIES (OPTIONAL)

Remote Control with Room Thermostats

Product Code	Product Name	Explanation	Product View
153.11.660.600020	WT-07 Cabled Room Thermostat	With minimal dimensions and decreased 4 button keypad Remote control which is connected to boiler with cable can work in modulation, run weekly programs, adjust hot usage water and show boiler fault code in the screen and reset it. Daily 8 program can be applied for adjusting heating and Domestic Hot Water (Hot Water Storage Tank).	
153.11.660.600021	WT-08 Cabled Wide Screen Room Thermostat	This remote control unit, which also has room thermostat feature, is connected to the combi boiler with cable and has 10-button keypad, where each function is assigned separately. This remote control features work in modulation, runs weekly programs, has DHW adjustment, shows boiler fault code on the screen and reset it.	
153.11.660.600022	WT-RF03 Wireless Wide Screen Room Thermostat	This remote control unit, which also has room thermostat feature, is connected to the combi boiler with wireless and has 10-button keypad, where each function is assigned separately. This remote control features modulated operation according to room temperature, weekly programs, DHW adjustment and display of the boiler fault code on the display and reset it. There are 6 daily programs for heating and DHW heating. Daily 6 program can be applied for adjusting heating and Domestic Hot Water (Hot Water Storage Tank).	

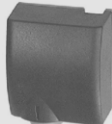
System Accessories

Product Code	Product Name	Explanation	Product View
153.11.660.600046	MLC 27-Cascade Module	Control unit ensures Enerwa Plus H boilers to work as cascade.	
153.11.660.600047	MLC 30-Multiple Zone Module	Control unit which controls Enerwa Plus H boilers low temperature/ Floor Heating Zone (mix fledged circuit).	
153.11.660.600049	QAZ36-Immersion Boiler / Hydraulic Separator Sensor	Immersion Sensor which is used to measure the temperature of Boiler or Hydraulic Separator and inform to the boiler.	
153.11.660.600050	QAD 36-Strap-on Temperature Sensor	Strap-on Temperature Sensor which ensures the measure of temperature on pipe at hydraulic separator. It is used to measure the temperature of flow water of low heating zone at the double heating zone.	
152.11.003.000004	AVC 220 Motorized Three Port Valve	It is the accessory that is used if it is requested to connect one hot water tank to single boiler and controlled by three port valve. This product must be used with "Boiler/ Hydraulic Separator Sensor".	
153.11.660.600001	WDHS-01-Outside Sensor	It is the sensor which measures the outside air temperature and inform maximum flow water temperature to the boiler. A single boiler heating system or cascade heating systems must be used with one Outside Sensor to save fuel.	

Look at The Technical Catalogue for detailed information.



2.4.1. Components of the Boiler

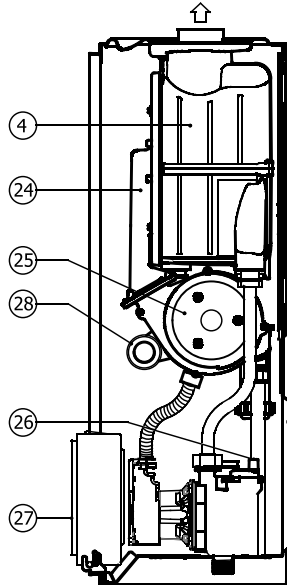
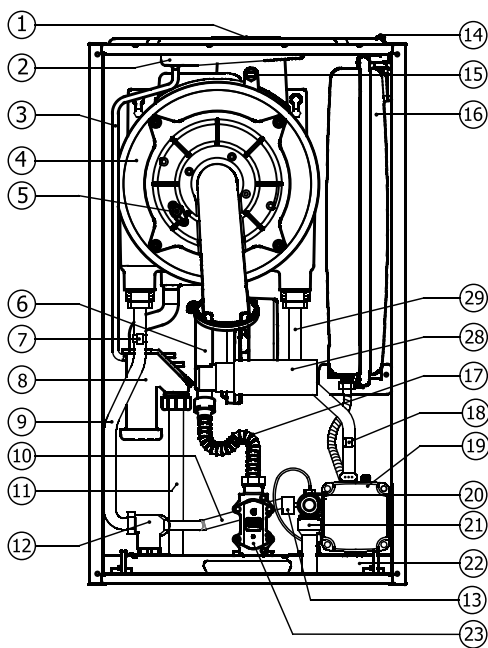

1. Flue Outlet
2. Flue Condensation Pan
3. Condensat Water discharge Hose
4. Main Heat Exchanger
5. Ignition Electrode
6. Air Gas Mixing Unit (AGM)
7. CH NTC Sensor
8. Condensation Water Trap (Siphon)
9. Radiator Outlet (Flow) Pipe
10. By Pass Pipe
11. Condensation water Discharge Hose
12. Output Manifold
13. Water Pressure Sensor
14. Expansion Tank Air Valve
15. Flue Gas NTC Sensor
16. Expansion Valve
17. Gas Inlet Pipe
18. CH Return NTC Sensor
19. Pump
20. Input Manifold
21. 3 Bar safety Valve
22. Manometer
23. Gas valve
24. Heat Exchanger Door
25. Electronic Fan
26. Automatic air relief Valve
27. Control Panel
28. Silencer
29. Radiator Inlet (Return) Pipe

Figure 42 Components of the Boiler

3. FOR USERS

3.1. GENERAL WARNINGS FOR USERS

3.1.1. Use of the Boiler

If you sense gas odor, first close the gas valves of the boiler and gas intake line of your house or valves of LPG (LNG) tanks if you use bulk gas. Do not turn on-off electricity switches, and do not do anything that may generate sparks. Call gas company or authorized service (See 1.3 Gas leaks)

Start-up of your boiler must be carried out by Warmhaus Authorized service in order to maintain warranty scope of your boiler. After our Authorized Service have carried out start-up checks and started your boiler, they shall inform you about use of the boiler.

Carry out the following checks prior to use:

- Ensure that; radiator/heating system and gas valves under the boiler are open,
- The heating system pressure read on the manometer under the boiler is between 1 - 1,5 bar, and system air has been purged, boiler valves are open if there is a boiler connection in the system,
- There is gas in your gas supply line (you can check by turning on one of the gas burning appliances),
- Electrical switch of the boiler is turned on,
- There are not any flammable materials or products near the boiler,
- The exhaust gas flue set is not blocked,
- Room thermostat(s) or control device is at ON position (if applicable).
- Follow the procedure given below if you are not going to use, and shut down the boiler in winter season with frost conditions:



- Drain the heating system water which does not contain antifreeze.
- Turn off the electrical switch, gas valve of the boiler, heating and domestic hot water!

Follow the steps given below if you are going to turn off the boiler for a short term:

- Do not turn off the electrical switch, gas valve of the boiler, heating and domestic hot water!
- Leave the boiler in Stand-by (OFF on the display) position, thus Anti-Frost Function will be enabled.

Turn off the boiler during maintenance and repair operations near the exhaust gas discharge flues. Have your boiler checked by Warmhaus Authorized Service prior to turning on the boiler after such maintenance.

Follow the rules specified below:

- Do not clean the outer body of the boiler while the boiler is operating, and do not use flammable materials for cleaning.
- Do not touch the boiler with wet hands or feet; or with bare hand or without footwear.
- Do not pull electrical cables.
- If the cables are damaged, turn off the boiler and switches, and do not use the boiler!
- Electrical cables of the boiler and its accessories shall be replaced only by the Authorized Service.
- Do not expose the mounted boiler to any vapors resulting from cooking.
- Prevent use of the boiler by children and unexperienced persons.

3.2. SELECTION OF ON / OFF / STAND-BY AND SUMMER / WINTER MODES

Use V circuit breaker (switch) to disconnect the boiler from power supply. When the appliance is energized, heating temperature on the left-hand side of the screen and hot domestic water temperature (if an HDW boiler is fitted) on the right-hand side of the screen shall be displayed.

3.2.1. On/Off/Stand-by Positions

Use V circuit breaker (switch) to turn on/off power supply connection of the boiler.



3.2.2. Operation in Winter Mode

When the boiler is in this position, it operates both for heating the ambient (if a boiler is fitted) and producing domestic hot water.

3.2.3. Operation in Summer Mode

The boiler operates only for domestic hot water in this mode, if a boiler is fitted. To switch to domestic water position;

3.2.4. Resetting the Boiler (Restart)

When the appliance shows fault/blocking error, push RESET button for 3-4 seconds, then release the button when the cycle on the display has been completed. When the appliance is reset, you can follow the normal operation procedure to restart operation.

3.2.5. Turning off the Boiler

Operation modes and indicators:

MODE DESCRIPTION :

- OFF (LCD display with 3 digits)
- WINTER ► Heating system temperature + °C + tap + radiator are displayed (if a boiler is fitted).
- SUMMER ► Heating System Temperature + °C + tap are displayed.
- HEAT. ON ► Heating System Temperature + °C + tap + blinking radiator (symbol) are displayed.
- HDW ON ► HDW Temperature + °C + blinking tap (symbol) are displayed (if a boiler is fitted).
- HEAT. ANTI-FROST ► Heating system temperature + °C + blinking radiator (symbol) + flame (symbol) when the burner is activated, are displayed.
- HDW ANTI-FROST ► Heating system temperature + °C + blinking radiator (symbol) and tap (symbol) + flame (symbol) when the burner is activated, are displayed.
- HEAT./DHW SETTING ► Changing the HEAT. setting, radiator symbol will be activated by quickly blinking. Changing the DHW setting, tap symbol will be activated by quickly blinking
- (Only for Authorized Service, in this case wait until completion of the function without pushing any button!)

HEAT.: Heating System **HDW:** Hot Domestic Water

3.2.6. Selection of On/Off/Stand-by and Summer/Winter Modes

The boiler panel does not have **ON/OFF** button. The boiler must be turned on/off by using the V circuit breaker to be connected to the boiler circuit.



When the boiler is turned on for the first time, nG symbol and then a number indicating kW power of the appliance (e.g. 50) will be displayed.



Then OFF will be displayed, and,



Display light will turn off. The combi is now in STAND-BY mode. When the appliance is energized, the temperature value is the temperature of the water in the system.

Control Panel of Enerwa Plus H Boilers

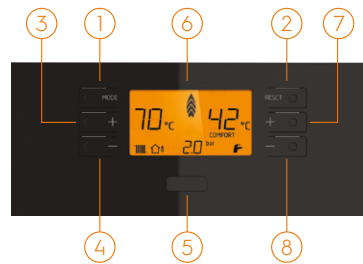

Figure 43 Control Panel of Enerwa Plus H Boilers

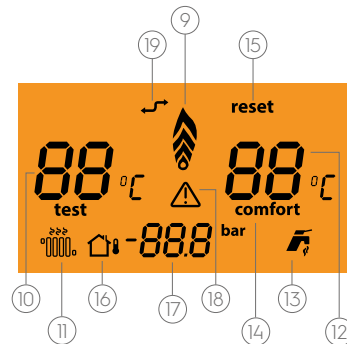

Figure 44 Control Panel View of Enerwa Plus H Boilers

BUTTONS and PUSH BUTTONS

1. MODE mode setting button.
2. RESET button.
3. Heating system temperature increasing button.
4. Heating system temperature reducing button.
5. Firmware connection socket.
6. Digital display.
7. Hot Domestic Water temperature increasing button (activated if a boiler is fitted)
8. Hot Domestic Water temperature reducing button (activated if a boiler is fitted)
9. Flame modulation indicator
10. Heating system water temperature (displayed if a boiler is fitted).
11. Heating system operation mode indicator (displayed if a boiler is fitted)
12. Hot Domestic Water temperature.
13. Hot Domestic Water operation mode indicator.
14. Operation in comfort mode.
15. Fault, need for RESET.
16. Outside Temperature Sensor connection indicator
17. Digital manometer (Heating system pressure 1.3 bar warning symbol; if the pressure is under this value, E02 error code will be displayed)
18. Fault indicator
19. Firmware connection symbol

The temperature value displayed on the boiler display have $\pm 3^{\circ}\text{C}$ tolerance which is not caused by the boiler, but depends on environmental conditions.

Display of Enerwa Plus H boilers with amber colored background light LCD display with 6 buttons: RESET, MODE, HEAT. (+), HEAT. (-), HDW (+), HDW(-) push

HEAT: Heating; HSW: Hot Domestic Water

RESET: Used for restarting the combi boiler and eliminating the fault in case of a fault.

MODE: Used for Winter/Summer/OFF mode setting.



3.2.7. On/Off/Stand-by Positions

The boiler panel does not have ON/OFF button. The boiler must be turned on/off by using the V circuit breaker to be connected to the boiler circuit.

3.2.8. Operation in Winter Mode

When the boiler is in this position, it operates both for heating the ambient (if a boiler is fitted) and producing domestic hot water. Heating system temperature setting set with no (3) and (4) buttons in Figure 43, and Hot Domestic Water temperature is set with no (7) and (8) buttons, and this temperature is shown on this display with no (10) indicator for Heating system and no (12) indicator for Hot Domestic Water.



When **OFF** symbol is displayed, keep **MODE** button pushed.



A cycle appears on the display.



Release the button when cycle is completed.



In this case the boiler switches to Heating mode, symbol blinks at lower-left part of the display, and tap symbol appears on the display (if a boiler is fitted). In this mode, a digital manometer appears at lower-middle of the display, and Current heating system temperature is displayed simultaneously, then background light turns off



An analogue manometer is placed near lower-right side of the boiler. System pressure can be read from this manometer even when there is no power.

Flame modulation symbol appears on middle part of the display when boiler starts operating. In this mode, you can adjust the temperature with temperature setting buttons (see Figure 43) temperature can be increased with (3) and reduced with (4) set between 35–80 °C, when these buttons are pushed, background light turns on and °C symbol and symbol blinks next to the temperature value.



{If you have an underfloor heating system, the temperature adjustable by the Heating temperature setting buttons (3) will be limited to the maximum temperature value (e.g. Maximum 47 °C) as your boiler will have been set to "Low Temperature Operation" by the Authorized Service}

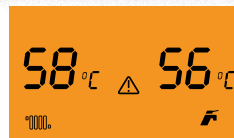

Hot Domestic Water Setting in Winter Mode (If a boiler is set);

In this mode, you can set the Hot Domestic Water temperature with (7) and (8) buttons under the **RESET** button on symbol side between 35 – 60 °C. Background light turns on while changing the temperature, °C symbol and symbol blinks next to the HDW temperature value. Background light turns off after setting.

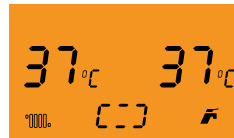

When starting the boiler for the first time, keep **MODE** button pushed until the cycle on the display is completed, the boiler will first switch to Heating mode, symbol will blink on the lower-left part of the display, and current heating system temperature will appear on the display, then background light will turn off.



Push **MODE** button again to switch to domestic water mode, then release the button when the cycle on the display is completed. In this mode, the symbol will blink on the lower-right corner of the display, and current domestic water temperature will appear on the display, then the background light will turn off. When you are going to switch to the summer mode from winter mode, push **MODE** button, and The boiler will be in **Summer** mode when cycle is completed.



In this mode, you can set the hot domestic water temperature with no (7) and (8) buttons under the **RESET** button (the side with symbol) between 35 – 60 °C.

Background light turns on while changing the temperature, °C symbol and symbol blinks next to the HDW temperature value. Setting value will be confirmed when background light turns of after setting

Turning off the Boiler

To turn off the boiler while operating in SUMMER mode;





When **MODE** button is pushed, the background light will be on until the cycle is completed, the background light turns off when **OFF** symbol appears on the display, and now your combi boiler is in **OFF** mode



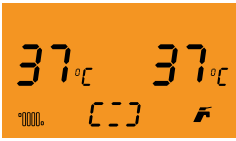

To turn off the boiler while operating in SUMMER mode;



Push **MODE** button, when background light is on  the boiler will first switch to **SUMMER** mode



Then repeat the same steps, after cycle is completed **OFF** will appear on the display and background light will turn off, your boiler is now in **STAND-BY** mode

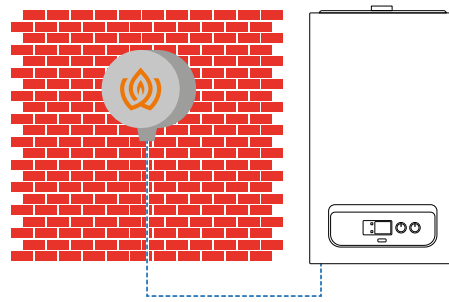

Figure 45 Outside Temperature Sensor

3.2.9. Operation in Summer Mode (if a boiler is fitted);

The boiler operates only for domestic hot water in this mode. To switch to domestic water position;

3.2.10. Use with Room Thermostat (Optional)

The boiler is readily suitable for connection of ambient thermostats with remote control sold as optional set. All Warmhaus thermostats can be connected with dual-wired cable. Read the operation and installation instructions in the accessories set. You can control your boiler from anywhere (e.g. Your living room) thanks to the control units with room thermostats and program clock, and even use it in different modes and temperatures on different days of the week.



Important: If any thermostat is on/off used with remote control, it must have two separate lines in accordance with the legislation in force. It is not permitted to use any pipe or hose of the boiler as electrical or telephone earthing line. Check this before making electrical connections of the boiler.

General Instructions of Use

- Consult our authorized services for room thermostats compatible with Warmhaus boilers.
- Do not disassemble any parts while the appliance is operating.
- Do not place the appliance in areas exposed to direct sunlight or near any heat sources.
- The manufacturer may not be held responsible for:
 - a) Incorrect installation
 - b) Intervention on the appliance by unauthorized person(s)
 - c) Noncompliance with the instructions given in this manual and manuals of the room thermostat.

3.2.11. Use of Outside Temperature Sensor (Optional)

Installation Section; Accessories Connection Diagram) upon your request allows automatic setting of the heating system temperature by instantly responding to changes in outside temperature with Smart and comfortable operation. Thus, it allows an efficient operation and saving energy by reducing the heating system water temperature as the outside temperature increases, and increasing the heating system water temperature as outside temperature decreases which provides much more comfort without need to manual setting. This sensor is activated when connected as independent from presence or type of room thermostat, and the correlation between the supply temperature of the system and outside temperature is determined depending on the position of the button on the control panel, and according to the curves given below.

After connecting the Outside Temperature Sensor, by means of the P04 parameter

It is adjusted according to average outside temperature of your province. This setting will be performed by the Authorized Service during installation.

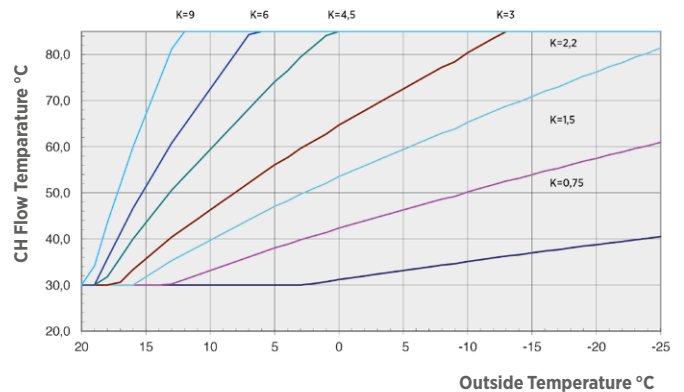

Figure 46 Outside Temperature Sensor Curves

Maintenance and Service Life: Maintenance and service life: The Warmhaus room thermostat should not come into contact with water or excessive moisture. Your room thermostat does not require any maintenance unless there is damage from outside. The service life is 5 years.

3.2.12. Customization of Boiler Functions

As the boiler has an advanced electronic card, certain parameters related to operating conditions and your preferences can be set by our Authorized Service. Please consult our Authorized Service when you desire to change the parameters given below.

(P06) Heating System (Heating) Power.

The boiler is fitted with an electronic modulation with a capacity suitable for actual heat requirement of the installation place. Thus, the boiler automatically operates between minimum power and maximum power with varying gas flow rates depending on the heat demand of the system.

(P07) Controlled Power Increase Duration.

When the boiler starts operating, it uses a controlled duration for reaching preset maximum heating power. This time is set as 3 minutes as default, and it can be extended up to 10 minutes.

(P21) Selection of low temperature zone.

This parameter shall be set as 1 for underfloor heating or other heating systems operating at low temperature. The 0 (zero) value shall be selected for systems operating at high temperature (radiator systems).

(P24) Child Protection

This parameter is not enabled as default, apply to our Authorized Service to enable the parameter (protection lock is activated when Parameter is set as 1). When the function is enabled keys will be locked approximately 2 minutes after use of the keys. Push MODE button until the cycle is completed to unlock the keys and exit child protection mode. Your appliance will be protected against any unintended changes in setting by activating this function.



(P40) Heating ignition delay time.

The boiler appliance is equipped with an electronic timer in order to prevent frequent ignition of the boiler. This time is set as 2 minutes as default, and it can be extended up to 10 minutes.

water consumption while waiting. This function can be enable or disable on 6-button Enerwa Plus H models. Preheat function is enabled when hot water temperature increasing RESET button is pushed until the cycle is completed. Pre-On or Pre-Off is displayed on the LCD display for 5 seconds at the end of this time.

(P42) Ready Hot Water (Preheat enabled/disabled).

This function heats up the boiler and keep water hot in order to prepare your Hot Domestic Water request immediately as well as to reduce cold

Activation of this function in Enerwa Plus H models is carried out by our Authorized Service with parameter setting upon your request.

3.3. TROUBLE SHOOTING

3.3.1. Error Code Table

Error Code	Error	Fault	Possible Cause	Solution(s)
E 01	Exhaust gas Thermostat (boiler with open combustion) intervention	The boiler does not operate, E01 error code blinks	> Exhaust gas sensor fault	1-) Restart the boiler by pushing RESET button. 2-) Call the authorized service if fault remains unsolved.
E 02	Water pressure in the system is low/system parameters are set incorrectly	The boiler does not operate, E02 error code blinks	> Water pressure in the boiler is not sufficient > TsP parameter is set incorrectly	1-) Fill the boiler up to 1,2-1,5 bar as specified in the manual, the problem will be automatically solved. 2-) Check if the system pressure is 1,2-1,5 bar from the manometer on the lower right side of the boiler 3-) Call Authorized service if the fault remains unsolved 4-) Restart the boiler by pushing RESET button.
E 03	High water pressure in the system	The boiler does not operate, E01 error code blinks	>Water pressure in the system is higher than 3,8 bars	1-) Drain the boiler down to 1,2-1,5 bar as specified in the manual, the problem will be automatically solved 2-) Check if the system pressure is 1,2-1,5 bar from the manometer on the lower right side of the boiler 3-) Call Authorized service if the fault remains unsolved. 4-) Restart the boiler by pushing RESET button.
E 04	Hot Domestic Water temperature sensor is faulty	The boiler does not operate in Hot Domestic Water mode, but operate in Heating system mode, E04 Error Code blinks on the display	> Hot Domestic Water temperature sensor is faulty	1-) Restart the boiler by pushing RESET button. 2-) Call the authorized service if fault remains unsolved.
E 05	Heating system supply temperature sensor is faulty	The boiler does not operate, E05 error code blinks	> Heating system supply temperature sensor is faulty	1-) Restart the boiler by pushing RESET button. 2-) Call the authorized service if fault remains unsolved.
E 06	No ignition	The boiler does not operate, E06 error code blinks	> Gas Supply fault	1-) First restart the boiler by pushing RESET button, and check if problem is solved 2-) Check if other appliances burning gas are operating. 3-) Check if the main gas valve is open. 4-) Check if the boiler gas valve under the boiler is open. 5-) Restart the boiler by pushing RESET button, and check if problem is solved. 6-) Call the authorized service if not solved.
E 07	Safety Thermostat intervention	The boiler does not operate, E07 error code blinks	> Insufficient water in the system > Pump clogging > Pump Failure > Pump Equipment clogging	1-) First restart the boiler by pushing RESET button, and check if problem is solved 2-) Check if the boiler heating system valves are open, if not, open all of them. 3-) Check if all radiator valves are open, if not open, minimum 3 meter-radiators must be on. 4-) Restart the boiler by pushing RESET button, and check if problem is solved. 5-) Call the authorized service if not solved.
E 08	Flame circuit fault	False flame signal from burner or electrode	> Wearing or corrosion of electrode > Electrode position > Interruption on cable > Water clogging in water flow pipe > Electronic card	1-) Restart the boiler by pushing RESET button. 2-) Call the authorized service if fault remains unsolved.
E 09	No water circulation in the system	The boiler does not operate, E09 error code blinks	> Insufficient water in the system, > Pump clogging, > Pump Failure, > Pump Equipment clogging	1-) Restart the boiler by pushing RESET button, and check if problem is solved. 2-) Check if the boiler heating system valves are open, if not, open all of them. 3-) Check if all radiator valves are open, if not open, minimum 3 meter-radiators must be on 4-) Restart the boiler by pushing RESET button and check if the problem is solved
E 10	Heating temperature RETURN sensor is faulty	The boiler does not operate, E10 error code blinks	> Heating system RETURN temperature sensor is faulty	1-) Restart the boiler by pushing RESET button. 2-) Call the authorized service if fault remains unsolved.



Error Code	Error	Fault	Possible Cause	Solution(s)
E 11	Gas valve modulator is not connected	The boiler does not operate, E11 error code blinks	> Gas valve line	1-) Restart the boiler by pushing RESET button. 2-) Call the authorized service if fault remains unsolved.
E 12	Hot Domestic Water temperature fault in summer mode	The boiler does not operate, E12 error code blinks	> Hot Domestic Water temperature sensor in the boiler is faulty	1-) Restart the boiler by pushing RESET button. 2-) Call the authorized service if fault remains unsolved.
E 13	Exhaust Gas Temperature Sensor excessive temperature alarm	The boiler does not operate, E13 error code blinks	> Excessive gas temperature outlet value > 105°C	1-) Restart the boiler by pushing RESET button. 2-) Call the authorized service if fault remains unsolved.
E 14	Exhaust Gas (FLUE) Temperature Sensor fault	The boiler does not operate, E14 error code blinks	> Heating system Exhaust Gas Temperature sensor is faulty	1-) Restart the boiler by pushing RESET button. 2-) Call the authorized service if fault remains unsolved.
E 15	Fan fault (feedback/supply)	The boiler does not operate, E15 error code blinks	> Fan system	1-) Restart the boiler by pushing RESET button. 2-) Call the authorized service if fault remains unsolved.
E 16	Heating temperature RETURN sensor is faulty	The boiler does not operate, E10 error code blinks	> Heating system RETURN temperature sensor is faulty	1-) Restart the boiler by pushing RESET button. 2-) Call the authorized service if fault remains unsolved.
E 17	Temperature difference between SUPPLY and LIMIT NTC (Dual Heating Sensor) is faulty	> SUPPLY AND LIMIT Sensor (dual NTC) is faulty	> SUPPLY AND LIMIT Sensor (dual NTC) is faulty	1-) Restart the boiler by pushing RESET button. 2-) Call the authorized service if fault remains unsolved.
E 19	Input measurement of water flow selection with water flow meter	Inadequate internal heating water upon demand	Parameters are set incorrectly on TsP menu	1-) Call the authorized service first 2-) TsP Parameter P01=0 default value must be set only by the authorized service
E 20	Heating system Excessive Temperature, Radiator Heating Temperature > TSP 81 value °C	The boiler does not operate, E81 error code blinks	> Insufficient/no water in the system > Pump clogging > Pump fault > Pump equipment > Installation clogging	1-) First restart the boiler by pushing RESET button, and check if problem is solved 2-) Check if the boiler central heating system valves are open, if not, open all of them 3-) Check if all radiator valves are open, if not open, minimum 3 meter-radiators must be on 4-) RESET the boiler, and check if the problem is solved 2-) Call Authorized service if the fault remains unsolved.
E 21	Delta Temperature Radiator Heating supply and Return > TSP 82 value °C	The boiler does not operate, E21 error code blinks	> Insufficient/no water in the system > Pump clogging > Pump fault > Pump equipment > Equipment clogging	1-) Restart the boiler by pushing RESET button, and check if problem is solved. 2-) Check if the boiler heating system valves are open, if not, open all of them. 3-) Check if all radiator valves are open, if not open, minimum 3 meter-radiators must be on 4-) Restart the boiler by pushing RESET button, and check if problem is solved. 5-) Call Authorized service if the fault remains unsolved.
E 28	Permitted maximum consecutive number of resetting is reached	Permitted number of RESET is reached.	Due to other possible causes, too many consecutive blocking (subsequently resetting) fault	1-) Disconnect the power supply, and resetting will be permitted 2-) Find the root cause of the error code to solve 3-) Call Authorized service if the fault remains unsolved.
E 37	Abnormal low voltage	The boiler does not operate, E01 error code blinks	Low voltage in < 165 VAC Electricity mains operation mode +/- %5 OR in Automatic calibration mode < 182 VAC +/- %5	1-) Restart the boiler by pushing RESET button. 2-) Call the authorized service if fault remains unsolved.
E 40	Incorrect mains frequency measurement	The boiler does not operate, E40 error code blinks	Incorrect frequency measurement, in mains different than 50 Hz +/- %5	1-) Call the electricity company 2-) If the supplied frequency is 50 Hz +/- %5, the fault will be solved
E 41	More than 6 consecutive ignition loss	The boiler does not operate, E41 error code blinks	> Too much domestic water demand within a short period (1 minute) > Low gas pressure	1-) Restart the boiler by pushing RESET button. 2-) Call the authorized service if fault remains unsolved.
E 42	Button failure	The boiler does not operate, E42 error code blinks	Parameters are set incorrectly on TsP menu	1-) Call Authorized service if the fault remains unsolved.
E 43	Room thermostat (Opentherm) communication error	The boiler does not operate, E43 Error Code blinks on the display after 1 minute communication error	Room thermostat (Opentherm) line connection interrupted	1-) Cut power of the boiler and E43 will disappear when re-energized, and the boiler and buttons will be functional 2-) Replace batteries of the room thermostat with new ones, and RESET the room thermostat. 3-) Check the cabling between the boiler and thermostat, and fix any interruptions, no 19 symbol will appear on the display if the connection is successful 4-) Call authorized service to re-connect the room thermostat (Opentherm).



Error Code	Error	Fault	Possible Cause	Solution(s)
rE 44	No combustion at burner despite many intermittent ignition	The boiler does not operate, E44 error code blinks	<ul style="list-style-type: none"> > Intermittent contacts on the system > Hammer impact on the water line > Too much demand within a short period from Outside Temperature Sensor units or thermostat bridge, etc. 	1-) Restart the boiler by pushing RESET button. 2-) Call the authorized service if fault remains unsolved.
E 62	Calibration demand	The boiler does not operate, E62 error code blinks	<ul style="list-style-type: none"> > Calibration not performed > PCB was replaced, but service key of the replaced was not used > Service key damaged or disconnected > Updating software (possible) 	1-) Restart the boiler by pushing RESET button. 2-) Call the authorized service if fault remains unsolved.
E 72	Delta T heating did not occur in combustion	The boiler does not operate, E72 error code blinks	<ul style="list-style-type: none"> > SUPPLY or RETURN Sensor is not in correct position 	1-) Restart the boiler by pushing RESET button. 2-) Call the authorized service if fault remains unsolved.
E 74	Second Heating System Temperature Sensor is faulty	The boiler does not operate, E74 error code blinks	<ul style="list-style-type: none"> > SUPPLY AND LIMIT Sensor (dual NTC) is faulty 	1-) Restart the boiler by pushing RESET button. 2-) Call the authorized service if fault remains unsolved.
E 77	Absolute current value is reached	The boiler does not operate, E77 error code blinks	<ul style="list-style-type: none"> > Gas Supply Pressure > Wearing or corrosion of electrode > Mixing of flue gas with fresh air > Clogging in flue or false flue > Electrode position > Interruption on cable > Burning calibration > Electronic board > Gas valve fault 	1-) Restart the boiler by pushing RESET button. 2-) Call the authorized service if fault remains unsolved.
E 78	Maximum regulating current value is reached	The boiler does not operate, E78 error code blinks	<ul style="list-style-type: none"> > Gas Supply Pressure > Wearing or corrosion of electrode > Mixing of flue gas with fresh air > Clogging in the flue or incorrect flue installation > Electrode position > Interruption on cable > Burning calibration > Electronic card > Gas valve fault 	1-) Restart the boiler by pushing RESET button. 2-) Call the authorized service if fault remains unsolved.
E 79	Minimum regulating current value is reached	The boiler does not operate, E79 error code blinks	<ul style="list-style-type: none"> > Gas Supply Pressure > Wearing or corrosion of electrode > Mixing of flue gas with fresh air > Clogging in the flue or incorrect flue installation > Electrode position > Interruption on cable > Burning calibration > Electronic card > Gas valve fault 	1-) Restart the boiler by pushing RESET button. 2-) Call the authorized service if fault remains unsolved.
E 80	Fault in electronic gas valve driver	The boiler does not operate, E80 error code blinks	<ul style="list-style-type: none"> > Electronic card > Gas valve fault 	1-) Restart the boiler by pushing RESET button. 2-) Call the authorized service if fault remains unsolved.
E 81	Ignition blockage during start (1)	The boiler does not operate, E81 error code blinks	<ul style="list-style-type: none"> > Excessive flue clogging > Ignition fault > False flue > Gas Supply Pressure > Wearing or corrosion of electrode > Recirculation in flue gas route > Electrode position > Burning calibration 	1-) Restart the boiler by pushing RESET button. 2-) Call the authorized service if fault remains unsolved.
E 84	Capacity reduction for detected (assumed) low gas supply pressure	The boiler does not operate, E84 error code blinks	<ul style="list-style-type: none"> > Gas Supply Pressure > Ignition fault 	1-) If wind velocity is high (e.g. windstorm) wait for the windstorm to stop, then restart the boiler by pushing RESET button. 2-) Call Authorized service if the fault remains unsolved.



Error Code	Error	Fault	Possible Cause	Solution(s)
E 87	Fault in electronic gas valve circuit	The boiler does not operate, E87 error code blinks	> Interruption on cable > Gas valve fault	1-) Restart the boiler by pushing RESET button. 2-) Call the authorized service if fault remains unsolved.
E 88	Fault in electronic gas valve circuit	The boiler does not operate, E88 error code blinks	> Interruption on cable > Gas valve fault	1-) Restart the boiler by pushing RESET button. 2-) Call the authorized service if fault remains unsolved.
E 89	Combustion feedback fault	The boiler does not operate, E89 error code blinks	> Wearing or corrosion of electrode > Mixing of flue gas with fresh air > Clogging in flue or false pipe > Electrode position > Interruption on cable > Burning calibration > Electronic card > Gas valve fault	1-) Restart the boiler by pushing RESET button. 2-) Call the authorized service if fault remains unsolved.
E 90	Failed to regulate combustion	The boiler does not operate, E90 error code blinks	> Wearing or corrosion of electrode > Mixing of flue gas with fresh air > Clogging in the flue or incorrect flue installation > Electrode position > Interruption on cable > Burning calibration > Electronic card > Gas valve fault	1-) Call the authorized service first. 2-) Check for false flue OR flue gas clogging. 3-) Restart the boiler by pushing RESET button. 2-) Call Authorized service if the fault remains unsolved.
E 92	Air balancing activated	The boiler does not operate, E91 error code blinks	> Possible wind > Wearing or corrosion of electrode > Mixing of flue gas with fresh air > Clogging in the flue or incorrect flue installation > Electrode position > Burning calibration > Minimum power setting	1-) Call the authorized service first. 2-) Check for false flue OR flue gas clogging. 3-) Restart the boiler by pushing RESET button. 2-) Call Authorized service if the fault remains unsolved.
E 93	Failed to regulate combustion (temporary)	The boiler does not operate, E93 error code blinks	> Wearing or corrosion of electrode > Mixing of flue gas with fresh air > Clogging in the flue or incorrect flue installation > Electrode position > Burning calibration > Gas valve fault > Electronic board	1-) Call the authorized service first. 2-) Check for false flue OR flue gas clogging. 3-) Restart the boiler by pushing RESET button. 2-) Call Authorized service if the fault remains unsolved.
E 94	Possible low gas pressure or exhaust recirculation	The boiler does not operate, E94 error code blinks	> Gas Supply Pressure LOW > Mixing of flue gas with fresh air > Clogging in the flue or incorrect flue installation > Wearing or corrosion of electrode > Electrode position > Burning calibration > Gas valve fault > Electronic board	1-) Call the authorized service first 2-) Check for false flue OR flue gas clogging. 3-) Restart the boiler by pushing RESET button. 2-) Call Authorized service if the fault remains unsolved.
E 95	Intermittent ignition value	The boiler does not operate, E95 error code blinks	> Electrode and earthing equipment > Wearing or corrosion of electrode > Electrode position > Burning calibration	1-) Restart the boiler by pushing RESET button. 2-) Call the authorized service if fault remains unsolved.
E 96	Clogging of flue or fresh air intake	The boiler does not operate, E96 error code blinks	> Clogging flue > Clogging in fresh air intake	1-) Call the authorized service first. 2-) Check for false flue OR flue gas clogging. 3-) Restart the boiler by pushing RESET button. 2-) Call Authorized service if the fault remains unsolved.
E 98	Software error, PCB start error fault	The boiler does not operate, E98 error code blinks	> Boiler software fault	1-) Restart the boiler by pushing RESET button. 2-) Call the authorized service if fault remains unsolved.
E 99	General fault	The boiler does not operate, E99 error code blinks	> Boiler electronic equipment fault	1-) Restart the boiler by pushing RESET button. 2-) Call the authorized service if fault remains unsolved.



3.4. RECOMMENDATIONS FOR ECONOMICAL USE OF THE BOILER

Your boiler is set in ECO mode for economical use, it is not recommended to change this setting.

Selection of Right Capacity

Heat loss of the ambient where the boiler is to be used shall be properly calculated, and boiler capacity shall be set accordingly. Appliances not having sufficient capacity will respond to demand more slowly, and appliances with higher capacities will lead to discomfort and more fuel consumption as they will be activated and deactivated more frequently. Therefore, suitable boiler capacity for the ambient to be heated.

Insulation

Insulation of your building is the most important factor preventing heat loss and reducing gas consumption. In addition, the insulation of your boiler is the thickest insulation within its class, thus heat loss is minimized.

Radiators

Adjust the radiator valves to balance pressure distribution of the system in your house. Placing furniture in front of radiators causes discomfort and higher fuel consumption. Reducing radiator valves or turning into the lowest position (thermostatic radiator valves) for the rooms which are not used for a long term, provides energy-saving.

Hot Domestic Water

If you are using the boiler with a hot domestic water boiler, it is recommended to set the Hot Domestic Water temperature as (38-42 °C). Setting the water heater to a low value provides a large amount of energy saving.

Thermostatic Radiator Valves

Use of Thermostatic Radiator Valves ensures balancing thermal distribution within your house, thus provides energy saving and comfort.

Room thermostats

Room thermostats allow setting ambient temperature for comfort and economic times, thus your boiler will operate more economically. Thus you can set your room temperature as you want, and make energy saving by 6% with each degree reduction.

Ventilation

Do not leave the windows half-open to ventilate room(s). In this case, while there will be no significant improvement in the room air quality, a continuous heat loss will take place. Opening windows fully for a short term gives more effective results.

Turn the thermostatic Radiator Valves to the lowest position when ventilating rooms.

3.5. MATTERS TO PAY ATTENTION FOR GUARANTEE CONDITIONS

This warranty provided by WARMHAUS does not include fixing or eliminating faults caused by use of the appliance for purposes other than intended use as well as the conditions specified below:

1. Damages and faults of the appliances start-up of which was not carried out by Warmhaus Authorized Service,
2. Damages and faults caused by improper use of the appliance and noncompliance with the terms and instructions in the Operation Manual,
3. Damages and faults caused by wrong selection of type,
4. Damages and faults caused by maintenance and reparation carried out by persons other than our Authorized Service,
5. Damages and faults caused by transport, unloading, loading, storage, external impact (crush, scratch, etc.) and chemical factors after delivery

of the product,

6. Damages and faults caused by fire and lightning stroke,
7. Damages and faults caused by use of incompatible fuel and fuel properties,
8. Excessive or low voltage; use of unearthed socket; damages and faults occurred in the faulty electrical installation,
9. Annual maintenance and cleaning which must be carried out by our Authorized Service,
10. Damages and faults caused by nonperformance of prescribed periodical maintenance,
11. Damages and faults occurred in the appliance or place of use due to other products and accessories used within the system together with the appliance subject to warranty.
12. Damages and faults caused by frost/freezing or use in areas exposed to atmospheric conditions (e.g. Open balcony, etc.).
13. Alteration of Registration Plate and Warranty Certificate,
14. Damages and faults caused by use of water out of values specified in the operation manual of the appliance,

Repair or elimination of faults specified below shall be charged.

The warranty applies only within the period specified on the reverse side of this certificate and for the faults occurred only on the appliance. Dear Customers, we believe in importance of providing high quality after sales services as well as a good product. Therefore, you can obtain information and contact our company in case of any service needs by calling;

Obligatory Recommendations and Important Information:

1. Preserve the technical service voucher provided by the Authorized Service for start-up of the boiler, a copy of the invoice of the appliance and the Warranty Certificate certified by Authorized Dealer.
2. Use your appliance in compliance with installation and operation manual.



TECHNICAL DATA		Unit	Enerwa Plus 2500 H				Enerwa Plus 3000 H				Enerwa Plus 3500 H			
CE Certificate			CE-1015CT0706 :18											
Gas Circuit														
Gas type		G20	G25	G30	G31	G20	G25	G30	G31	G20	G25	G30	G31	
Gas Supply Pressure	mbar	20	25	30	37	20	25	30	37	20	25	30	37	
Gas Consumption at Maximum	m ³ /h	2,38*	2,85	0,728	0,92	3,05*	3,47	0,857	1,18	3,402	4,127	0,992	1,302	
Gas Consumption at Minimum	m ³ /h	0,37*	0,43	0,107	0,11	0,397*	0,456	0,109	0,144	0,434	0,524	0,133	0,168	
*(Natural Gas G20) Heat Load (Hu=10,56 kWh/m ³)														
Premix System		Gas Adaptive*				Gas Adaptive*				Gas Adaptive*				
Modulation Rate		01:10				01:10				01:10				
Heat Exchanger Material		Stainless steel				Stainless steel				Stainless steel				
Efficiency														
		G20	G25	G30	G31	G20	G25	G30	G31	G20	G25	G30	G31	
(80/60 °C) Efficiency at Maximum Heat Output	%	98,03	97,84	97,48	97,76	97,88	98,15	97,57	98,59	98,00	98,23	97,61	98,04	
(50/30 °C) Efficiency at Maximum Heat Output	%	105,11	105,34	101,95	103,63	105,0	105,2	102,89	104,67	105,4	105,53	103,06	105,43	
Efficiency at 30% load at 36/30 °C	%	108,29	108,38	104,28	108,29	107,54	107,83	105,37	107,36	107,2	107,06	104,62	106,98	
Seasonal space heating energy efficiency (expressed in terms of GCV)	%	92 (Class A)				92 (Class A)				92 (Class A)				
Radiator Circuit														
		G20	G25	G30	G31	G20	G25	G30	G31	G20	G25	G30	G31	
Maximum heat input Qn	kW	24,25	24,25	24,25	24,25	28,7	28,7	28,7	28,7	33,7	33,7	33,7	33,7	
Minimum heat input Qn	kW	3,5	3,5	3,5	2,8	3,75	3,75	3,75	3,75	4,35	4,35	4,35	4,35	
Maximum Heat Output Pn (80/60 °C)	kW	23,7	23,7	23,6	23,7	28	28	28	28	33,02	33,02	32,8	33,02	
Minimum Heat Output Pn (80/60 °C)	kW	3	3	3,2	2,5	3,5	3,5	3,25	3,45	4,1	4,1	4,1	4,1	
Maximum Heat Output Pn (50/30 °C)	kW	25	25	24,70	25	30	30	29,5	30	35,5	35,5	34,7	35,5	
Minimum Heat Output Pn (50/30 °C)	kW	3,6	3,6	3,55	2,9	3,90	3,90	3,74	3,59	4,60	4,60	4,60	4,60	
Temperature selection range (min+max) high temperature	°C	25÷80				25÷80				25÷80				
Temperature selection range (min+max) low temperature	°C	25÷47				25÷47				25÷47				
Operating Pressure (Maximum)	bar	3				3				3				
Operating Pressure (Minimum)	bar	0,5				0,5				0,5				
Expansion tank useful volume	bar	8				10				10				
Pump pressure (at 1000 l/h flow rate)	mH ₂ O	5,5				5,5				5,5				
Pump pressure (at 500 l/h flow rate)	mH ₂ O	7,8				7,8				7,8				
Max. Pump Flow Rate	l/h	2400				2400				2400				
Pump Energy Efficiency Index (EEI)		≤ 0,20				≤ 0,20				≤ 0,20				
Electricity Circuit														
Electricity Supply	V AC-50 Hz	230 V +%10; -%15				230 V +%10; -%15				230 V +%10; -%15				
Electricity Consumption (Max./Min.)	Watt	95 / 55				104 / 60				115 / 65				
Protection Index	IP	IPX5D				IPX5D				IPX5D				
Exhaust Gas Circuit														
		G20	G25	G30	G31	G20	G25	G30	G31	G20	G25	G30	G31	
Flue temperature (Qn)														
(80/60 °C) Exhaust gas temperature (Min. / Max.)	°C	69,3/70,5	64,6/70,2	57,1/70,0	59,9/69,7	60,8/66,1	55,1/64,6	56,6/67,2	57,6/65,0	56,8/62,3	56,9/62,2	54,4/66,7	58,2/67,4	
(50/30 °C) Exhaust gas temperature (Min. / Max.)	°C	48,5/50,5	47,7/49,4	42,8/57,0	47,0/50,5	44,5/44,5	44,1/44,0	42,2/49,8	43,4/44,9	46,8/44,2	46,7/44,5	40,6/48,4	48,7/48,9	
Maximum exhaust gas temperature [Maximum DHW mode]	°C	70				70				70				
NOx	Class	6				6				6				
Weighted value of Nox (GCV)	mg/kWh	20	19	42	31	41	31	43	49	34	32	43	53	
Flue mass flow rate (60/80°C - Qn) Nominal/Minimum	g/s	10,32/1,6	10,78/1,62	10,58/1,26	9,91/1,18	13,23/1,72	13,13/1,73	12,29/1,56	12,71/1,62	14,76/1,88	15,54/1,97	14,28/1,97	14,03/1,81	
Flue mass flow rate (60/80°C - Qn) [Maximum DHW mode]	g/s	14,01	14,04	13,58	12,71	15,53	15,82	14,91	14,65	18,36	18,54	17,00	16,65	
Fan head loss	Pa	35 ÷ 140				35 ÷ 140				35 ÷ 140				
General														
Dimensions (H x W x D)	mm	725 x 420 x 288				725 x 420 x 288				725 x 420 x 288				
Sound Level	dB (A)	52				54				50				
Hydraulic Group Material		Brass				Brass				Brass				
Net Weight	kg	32,5				33,7				34,5				
Packed Device Weight	kg	34,7				35,9				36,7				
Type		B23, B23P, B33, C13, C33, C53, C63, C83, C93, C103												
Category		I2H, I2E, I2E(S) - (G20=20 mbar), I2E+, I2L, I2ELL - (G25=25 mbar) I3P - (G31=37 mbar) I3B/P - (G30=30 mbar)												

Gas Adaptive (*): This boiler fitted with gas/air ratio controls. Gas and air ratio control settings must not be changed un autorised persons. The gas valve calibration method is explained on service manual and has to be done by Warmhaus official service.



Product Fiche & ErP Data			
Designation : Product FICHE & ErP Data Enerwa Plus 2500 H - 3000 H - 3500 H			
Object	Manufacturer	Type-model / Technical data	Mark (s) of conformity
Product Fiche & ErP Data	Warmhaus	Enerwa Plus H boilers	granted

ErP & Product Fiche for Warmhaus boilers has been tested and reported on SZU Test / BRNO given below;

PRODUCT FICHE (according to EU regulation No 811/2013 and 814/2013)

			Enerwa Plus 2500 H	Enerwa Plus 3000 H	Enerwa Plus 3500 H
Space heating - Temperature application			High / Medium / Low	High / Medium / Low	High / Medium / Low
Water heating - Declared load profile			—	—	—
Seasonal space heating energy efficiency class			A	A	A
Water heating energy efficiency class			—	—	—
Rated heat output (Prated or Psup)		kW	24	28	33
Space heating - annual energy consumption	QHE	GJ	42,14	48,77	54,78
Water heating - Annual energy consumption		kWh (*)	—	—	—
		GJ (**)	—	—	—
Seasonal space heating energy efficiency		%	92	92	92
Water heating energy efficiency		%	—	—	—
Sound power level L_{WA} indoors		dB	52	54	50
Option to only operate during low demand periods			—	—	—
Specific precautions for assembly, installation and maintenance			Before any assembly, installation or maintenance the user and installation manual has to be read attentively and to be followed		

All the data that is included in the product information was determined by applying the specifications of the relevant European directives. Differences to product information listed elsewhere may result in different test conditions. Only the data that is contained in this product information is applicable and valid.

(*) Electricity
(**) Fuel

ErP DATA (according to EU regulation No 813/2013 and 814/2013)

			Enerwa Plus 2500 H	Enerwa Plus 3000 H	Enerwa Plus 3500 H
Water heating - Declared load profile					
Rated Heat Output	Prated	kW	24	24	33
Useful heat output at rated heat output and high temperature regime (2)	P4	kW	23,7	23,7	33,02
Useful heat output at 30% of rated heat output and low temperature regime (1)	P1	kW	4,16	4,87	5,71
Seasonal Space Heating Energy Efficiency	η_s	%	92	92	92
Useful efficiency at rated heat output and high temperature regime (2)	η_4	%	87,57	88,02	88,21
Useful efficiency at 30% of rated heat output and low temperature regime (1)	η_1	%	97,48	96,82	96,87
Auxiliary Electricity Consumption					
Full load	elmax	kW	0,43	0,57	0,54
Part load	elmin	kW	0,11	0,12	0,13
Standby mode	PSB	kW	0,005	0,005	0,005
Other Items					
Standby heat loss	PStby	kW	0,057	0,057	0,057
Ignition burner power consumption	Pign	kW	0,000	0,000	0,000
Space heating - annual energy consumption	QHE	GJ	42,14	42,14	54,78
Sound power level, indoors	LWA	dB	52	52	50
Emissions of nitrogen oxides	NOx	mg/kWh	20	20	34
Domestic Hot Water Parameters					
Declared Load Profile					
Daily electricity consumption	Qelec	kWh	0,117	0,169	0,190
Annual electricity consumption *	AEC	kWh	26	37	42
Water Heating Energy Efficiency	hwh	%	81	84	82
Daily fuel consumption	Qfuel	kWh	14,809	23,152	29,317
Annual fuel consumption	AFC	GJ	11	18	23
Condensing boiler			Yes	Yes	Yes
Low temperature boiler			Yes	Yes	Yes
Combination boiler			No	No	No
B1 Boiler			No	No	No
Room boiler with combined heat and power			No	No	No
Auxiliary boiler			No	No	No
Brand Name	Warmhaus				
Manufacturer adress	Warmhaus Isıtma ve Sogutma Sistemleri San. Tic. A.Ş. Nilufer Organize Sanayi Bolgesi Selvi Cad. No:3 Nilufer/Bursa/Turkey				
Warnings	All specific precautions for assembly, installation and maintenance are described in the operating and installation manual. Read and follow the operating and installation manual.				
	Read and follow the operating and installation manual regarding assembly, installation, maintenance, removal, recycling and/or disposal.				

* for average climatic conditions

(1) Low temperature means for condensing boilers 30 °C, for low temperature boilers 37 °C and for other heaters 50 °C return temperature (at heater inlet).

(2) High temperature regime means 60 °C return temperature at heater inlet and 80 °C feed temperature heater outlet.

ENERWA PLUS 2500 H

CE 1015 18

EAC LOGO

UKRSEPRO
LOGO

Weight: 35.9 kg
Size: 49x81x37 cm

EAN KODU

Production Date

SERİ NO

READ THE
INSTRUCTION
OF THE BOILER
BEFORE
INSTALLATION !!!

MADE IN TURKEY

I 2H	TR
II 2H3+	TR
I 3B/P	TR
II 2H3+	TR
I 3P	TR

Gas Categories	G20	G31	G30
Maximum heat input Qn [kW]	28,70	28,70	28,7
Minimum heat input Qn [kW]	3,75	3,59	3,75
Δt (80/60°)			
Maximum heat output Pn [kW]	28	28,01	28
Minimum heat output Pn [kW]	3,5	3,5	3,3

The maximum water pressure:	
The electrical supply:	-230V (+10%/-15%) and 50 Hz
The rated electrical power input:	104 W
The type of boiler:	Premix Condensing Boiler
Nominal heat input for DHW:	
Maximum water service pressure CH (PMS):	2,5 Bar
Protection class:	IP X5D

B₂₃, B_{23p}, B₃₃, C₁₃, C₃₃, C₅₃, C₆₃, C₈₃, C₉₃, C₁₀₃

2H-G20-20 MBAR

METANO
NATURAL GAS

 **warmhaus**

Warmhaus Isıtma ve Soğutma Sistemleri San. A.Ş.
Nispetiye Organize Sanayi Bölgesi, Selvi Caddesi, No: 3
Nispetiye 16140, Bursa, Türkiye
T: +90 224 295 94 00 F: +90 224 411 23 77 info@warmhaus.com.tr

ENERWA PLUS 3000 H

CE 1015 18

EAC LOGO

UKRSEPRO
LOGO

Weight: 36.7 kg
Size: 49x81x37 cm

EAN KODU

Production Date

SERİ NO

READ THE
INSTRUCTION
OF THE BOILER
BEFORE
INSTALLATION !!!

MADE IN TURKEY

Gas Categories	G20	G31	G30
Maximum heat input Qn [kW]	33,7	33,7	33,7
Minimum heat input Qn [kW]	4,35	4,35	4,35
Δt (80/60°)			
Maximum heat output Pn [kW]	33,02	33,02	32,8
Minimum heat output Pn [kW]	4,1	4,1	4,1

B₂₃, B_{23p}, B₃₃, C₁₃, C₃₃, C₅₃, C₆₃, C₈₃, C₉₃, C₁₀₃

2H-G20-20 MBAR

METANO
NATURAL GAS

I 2H	TR
II 2H3+	TR
I 3B/P	TR
II 2H3+	TR
I 3P	TR

The maximum water pressure:	
The electrical supply:	-230V (+10%/-15%) and 50 Hz
The rated electrical power input:	115 W
The type of boiler:	Premix Condensing Boiler
Nominal heat input for DHW:	
Maximum water service pressure CH (PMS):	2,5 Bar
Protection class:	IP X5D

 **warmhaus**

Warmhaus Isıtma ve Soğutma Sistemleri San. A.Ş.
Nispetiye Organize Sanayi Bölgesi, Selvi Caddesi, No: 3
Nispetiye 16140, Bursa, Türkiye
T: +90 224 295 94 00 F: +90 224 411 23 77 info@warmhaus.com.tr

ENERWA PLUS 3500 H

CE
1015 18

EAC LOGO

UKRSEPRO
LOGO

Weight: 34.7 kg
Size: 49x81x37 cm

EAN KODU

Production Date

SERİ NO

READ THE
INSTRUCTION
OF THE BOILER
BEFORE
INSTALLATION !!!

MADE IN TURKEY

I 2H	TR
II 2H3+	TR
I 3B/P	TR
II 2H3+	TR
I 3P	TR

Gas Categories	G20	G31	G30
Maximum heat input Qn [kW]	24,25	24,25	24,25
Minimum heat input Qn [kW]	3,5	2,8	3,5
Δt (80/60°)			
Maximum heat output Pn [kW]	23,7	23,7	23,6
Minimum heat output Pn [kW]	3,0	2,5	3,3

The maximum water pressure:	
The electrical supply:	-230V (+10%/-15%) and 50 Hz
The rated electrical power input:	95 W
The type of boiler:	Premix Condensing Boiler
Nominal heat input for DHW:	
Maximum water service pressure CH (PMS):	2,5 Bar
Protection class:	IP X5D

B₂₃, B_{23P}, C₁₃, C₃₃, C₅₃, C₆₃, C₈₃, C₉₃, C₁₀₃

2H-G20-20 MBAR

METANO
NATURAL GAS

 **warmhaus**

Warmhaus Isıtma ve Soğutma Sistemleri San. A.Ş.
Nilüfer Organize Sanayi Bölgesi, Selvi Caddesi, No: 3
Nilüfer 16140, Bursa, Türkiye
T: +90 224 224 295 94 00 F: +90 224 411 23 77 info@warmhaus.com.tr



ENERG Y UJA
енергия · енеруєт IE IA

warmhaus Enerwa Plus 2500 H

52 dB

24 kW

2015 811/2013

ENERG Y UJA
енергия · енеруєт IE IA

warmhaus Enerwa Plus 3000 H

54 dB

28 kW

2015 811/2013

ENERG Y UJA
енергия · енеруєт IE IA

warmhaus Enerwa Plus 3500 H

50 dB

33 kW

2015 811/2013



A series of horizontal grey lines for writing, spaced evenly down the page.



All descriptions and illustrations provided in this document have been carefully prepared but we reserve the right to make changes and improvements in our products which may affect the accuracy of the information contained in this leaflet. All goods are sold subject to our standard Conditions of Sale which are available on request.

Enerwa Plus 2500 H
Enerwa Plus 3000 H
Enerwa Plus 3500 H

**WALL-MOUNTED CONDENSING SYSTEM
BOILERS INSTALLATION AND USER MANUAL**

Enerwa Plus H Montaj & Kullanım Klavuzu kodu: 150.11.606.000065
Revizyon numarası: R00/04.2019